

Complete power supply solutions for medical locations with the regulation and control system *HospEC*[®]
 Overview catalogue

Our sales offices in your vicinity

HEADQUARTERS

ESA Elektroschaltanlagen Grimma GmbH
Broner Ring 30
D-04668 Grimma
Tel.: +49 (0) 3437 92 11-0
Fax: +49 (0) 3437 92 11-26
E-mail: info@esa-grimma.com
Internet: www.esa-grimma.com

ARNSBERG SALES OFFICE

ESA Elektroschaltanlagen Grimma GmbH
Asterwinkel 1
D-59755 Arnsberg
Tel.: +49 (0) 2932 89 11 87
Fax: +49 (0) 3437 92 11 20 310

RAUENBERG SALES OFFICE

ESA Elektroschaltanlagen Grimma GmbH
Römerstr. 2a
D-69231 Rauenberg
Tel.: +49 (0) 7253 93 49 42
Fax: +49 (0) 7253 93 49 48

NEUFAHRN SALES OFFICE

ESA Elektroschaltanlagen Grimma GmbH
Carl-Diem-Straße 12
D-85375 Neufahrn
Tel.: +49 (0) 8165 40 94 660
Fax: +49 (0) 3437 92 11 20 300



Grimma location:

Manufacture and administration on an area of 7000 m² – modern switch cabinet construction, CNC machining centre, electronics production, research and development



The corporation: ESA Elektroschaltanlagen Grimma GmbH

Expertise in low-voltage switch cabinets

ESA Elektroschaltanlagen Grimma GmbH is an expanding mid-sized company in the electrotechnical industry.

At its foundation in 1992, the company began with the manufacture of low-voltage switch cabinets. Today, we offer system solutions around the world for reliable power supply for railways, industry, buildings and hospitals.

- In-house technical innovations,
- Continuous product development,
- Technical expertise and experience,
- Quality, reliability and
- Service

establish the foundation for forward-looking technical solutions and shape the corporate philosophy of ESA Elektroschaltanlagen Grimma GmbH.

Always guiding our actions is the motto:
Utmost human and operational safety of our products!

Certified hospital quality

Our products and system solutions

- conform with the latest standards and regulations and
- are tested and certified by independent test laboratories.

We operate on the basis of a quality management system and are certified according to DIN ISO 9001:2000.

Take advantage of our years of experience to fulfil the unique requirements for reliable power supply in hospitals and medical facilities.

Our products

- Low-voltage switch cabinets in type-tested (TTA) and partially type-tested (PTTA) versions
- Regulation and control system for power supply of medical locations in accordance with IEC 60364-7-710:2002-11/ DIN VDE 0100-710:2002-11
- Annunciator and control panels in foil technology
- Insulation, residual and operating current monitoring systems

Services

- Consultation for developing designs
- Performing network analyses
- Planning and project management
- Instruction and training of your personnel
- Service by hotline
- Maintenance and repair service



Complete power supply solutions for medical locations with the regulation and control system *HoapEC*[®]

Requirements

The patient is at the heart of a hospital or a medical institution. An interruption of the power supply can lead to critical situations in the treatment and thereby endanger the health of the patients in extreme cases.

Thus, medical locations require highly modern, reliable electrical supply equipment. Keeping this in mind, the regulation and control system *HoapEC*[®] was developed by ESA Elektro-schaltanlagen Grimma GmbH for the reliable supply of hospitals. We thereby fulfil the highest requirements for the reliability of power supply in medical locations according to IEC 60364-7-710:2002-11 and DIN VDE 0100-710:2002-11.

Our solution *HoapEC*[®] – One system

The regulation and control system *HoapEC*[®] is an integrated system solution for reliable, convenient and economic power supply of hospitals. With our technology, we optimally realise all necessary regulation, monitoring and control tasks of a hospital or a medical institution.

The flexibility of *HoapEC*[®] allows for efficient application in the most diverse individual situations. The system impresses with its complex functionality and simple planning and installation. Significant cost advantages are also gained during operation and maintenance as well as during expansion or modification.

Your advantages

- Reliable monitoring, archiving, control and display of the operational status of the system according to standards
- Integrated concept with open system architecture
- Compatibility with third-party components through links with other bus systems via digital input/output modules and bus couplers
- Easy extension or adaptation by modular structure
- All information is available outside the sterile areas
- Realisation of energy, capacity and cost optimisation
- Cost and time advantages during planning, installation and operation
- High availability and reliability by mutual monitoring of all system components
- Expert service and maintenance

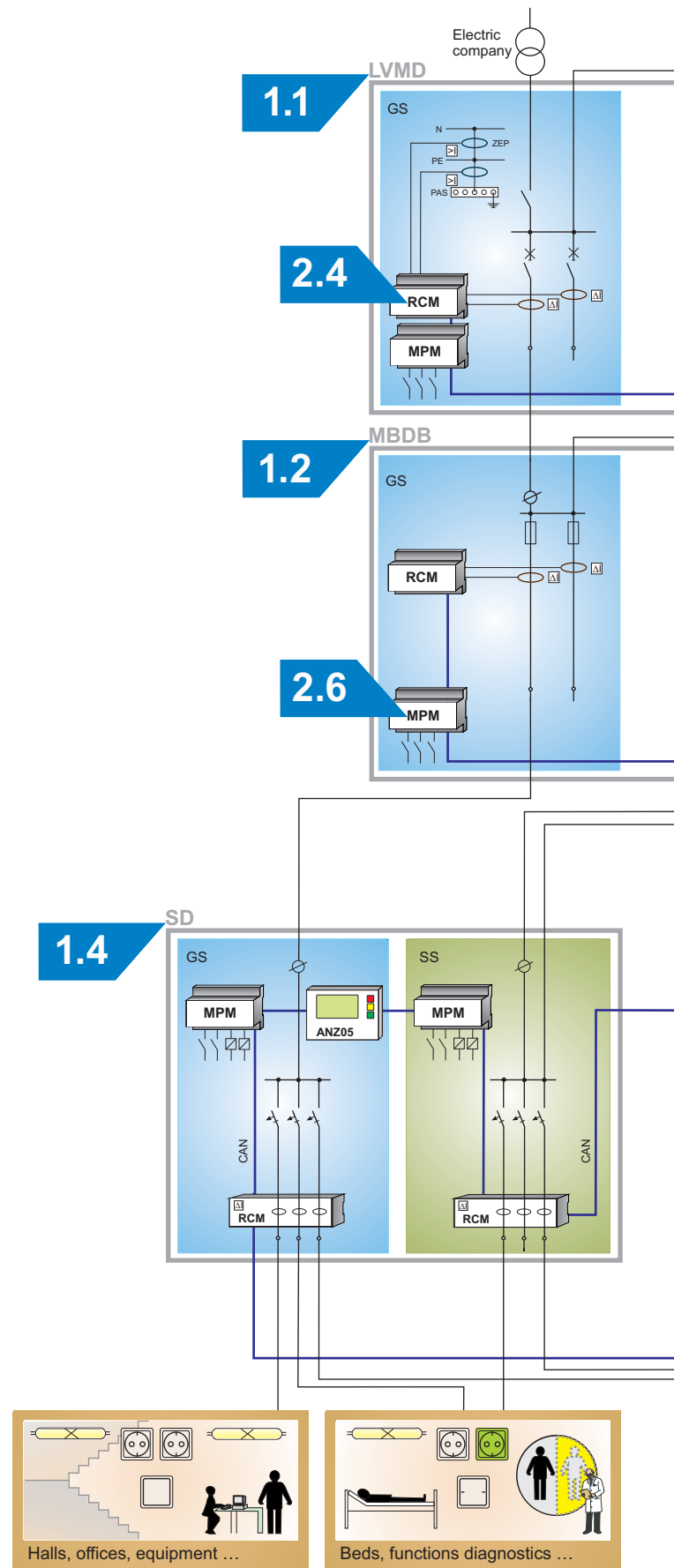

General areas

Group 0 and 1

HoapEC[®] – Overview model of switch cabinets and function systems in hospitals

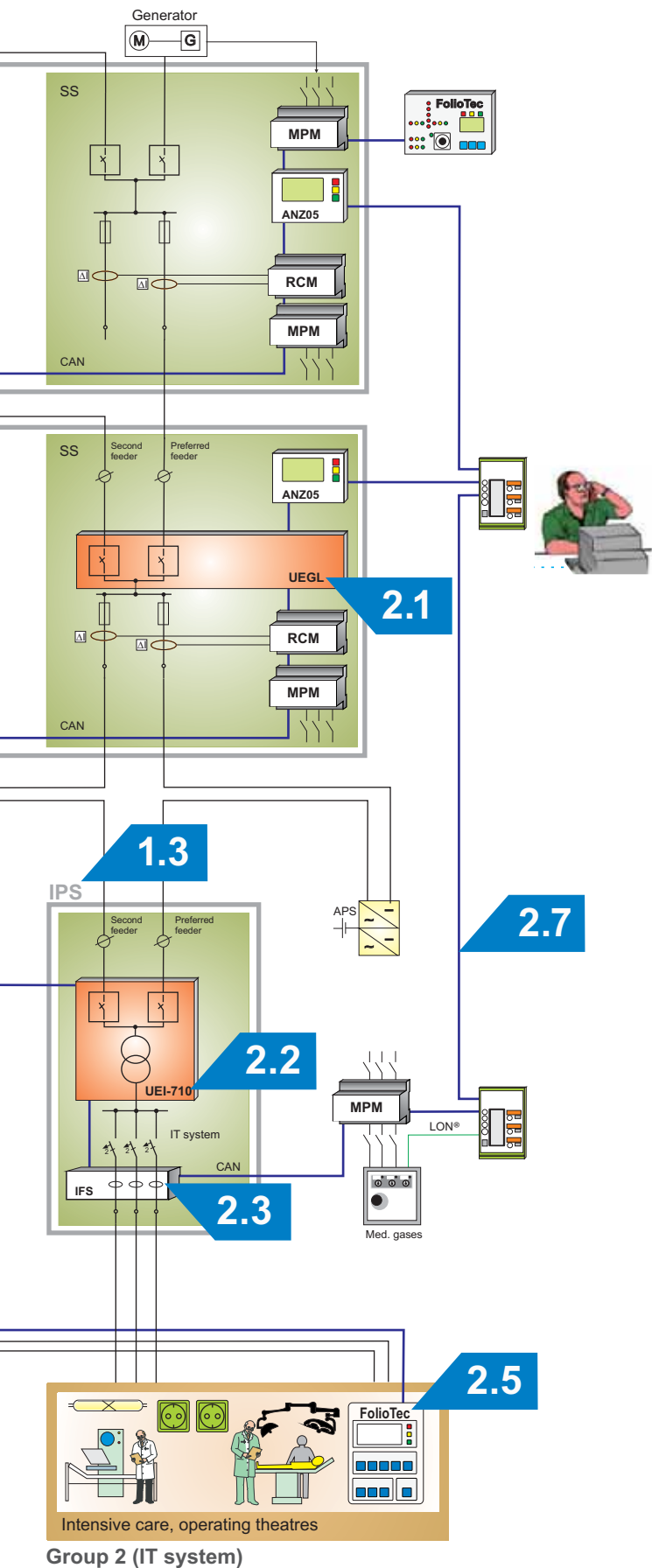

Product and systems for power supply in hospitals

- 1 Low-voltage switchgear and controlgear assembly
 - 1.1 Main distribution board LVMD
 - 1.2 Main building distribution board MBDB with change-over module *UEGL*
 - 1.3 IT system distribution board *IPS* for areas of group 2 with change-over and monitoring module *UEI-710* and insulation fault detection system *IFS*
 - 1.4 Subdistributor SD for areas of group 0 and 1 as well as for supplying general areas
- 2 Regulation and control systems *HospEC®*
 - 2.1 Change-over module *UEGL* for main building distribution boards
 - 2.2 Change-over and monitoring module *UEI-710*, *ÜEI-710* for IT system distribution board
 - 2.3 Insulation fault detection system *IFS*
 - 2.4 Residual and operational current monitoring system *RCM*
 - 2.5 Display and operating systems *FolioTec*, *BMTI S*, *ANZ OS*
 - 2.6 Lighting control/Linking to third-party systems with digital input/output devices *MPM*
 - 2.7 Standard field bus CAN
- 3 Regulation and control devices *HospEC®*

Quality and service from a single source

Constant monitoring of our own standard-compliant developments, also by independent test laboratories, ensures consistent, sound quality. Constant contact with experienced planning and test engineers as well as members of the standardisation boards (DKE) also guarantees utmost reliability.

Our engineering department is available to aid in your endeavours, and we provide comprehensive service – from the planning to realisation, including standard-compliant maintenance.

Main distribution board LVMD

1.1

Requirements

The main distribution board LVMD is the central switch cabinet within a hospital. In it the basic network structure for the general supply (GS) and the safety power supply (SS) are established. Due to their great importance, there are strict requirements on the operational reliability and person and system protection. Accordingly, the system must be configured as a type-tested low-voltage switchgear and controlgear assembly (TTA) according to DIN VDE 0660 Part 500, IEC 60439-1 and DIN EN 60439-1.

The solution

Our main distribution boards consist of:

- Incoming/Outgoing feeders general supply (GS)
- Incoming/Outgoing feeders safety power supply (SS)
- Compensation system

Project-specific extension with:

- Indicating panel for status indication of the generator incoming feeder – *FolioTec*
- Residual and operational current monitoring devices *RCM* for location and early detection of faulty outgoing feeders or consumers
- Switching of switch positions and coupling in of third-party systems by digital input/output devices *MPM* on the field bus (CAN)
- Display and configuration device *ANZ 05* for display of measured values as well as operational and fault messages
- Data connection to the regulation and control system *HotEC®* via field bus (CAN)

Your benefit

- Modular design of distribution, function systems and devices
- Individual planning, project management and execution for every individual situation
- Arc-fault safe insulation between common rail space, device space and connection space
- High operational reliability, personal safety, and availability
- Construction upon request, type-tested according to DIN VDE 0660 Part 500, IEC 60439-1 and DIN EN 60439-1
- Secure separation between the systems (GS and SS)

Our products

- Low-voltage switch cabinet (as main distribution board)
 - Control cabinet system GNS 3.1 – structurally identical with FourLine system made by Striebel & John (based on further developed MNS 3.0 system made by ABB)
 - Control cabinet system Sivacon – made by Siemens
- Regulation and control equipment system *HotEC®*
 - Indicating panel for the generator incoming feeder system *FolioTec*
 - Display and configuration device *ANZ 05*
 - Residual and operational current monitoring device *RCM*
 - Digital input/output devices *MPM* with data interface with standard field bus (CAN)



Switch cabinet, System GNS 3.1



Assembly of a switch cabinet

Technical specifications (system GNS 3.1)

Standards/construction	Type-tested switchgear and controlgear assembly TTA, IEC 60439-1/ DIN EN 60439-1/DIN VDE 0660 Part 500
Rated voltages and rated currents	
Rated impulse withstand voltage	8 kV
Overtoltage category	IV
Pollution degree	3
Rated operational voltage U_e	690 V AC/750 V DC
Rated insulation voltage U_i	1000 V
Rated frequency	50 Hz to 60 Hz
	Common rails/Field distribution rails
Rated current I_e	Up to 6300 A/up to 2000 A
Rated impulse withstand current I_{pk}	Up to 250 kA/up to 165 kA
Rated short-time withstand current I_{cw}	Up to 100 kA/up to 86 kA
Protection	
Surface protection	Frame – aluminium-zinc coating, cases, doors – steel panel/ powder-coated
Colour	Powder-coated RAL 7035 light-grey (special colours upon request)
Protection class according to DIN EN 60529	IP30 (IP00 to IP54 upon request)
Protection class	I (earthed)
Internal division	Form 1 to form 4b
Dimensions	
Height (mm)	2200
Width (mm)	200, 400, 600, 800, 1000, 1200
Depth (mm)	400, 600, 800, 1000, 1200
Raster size	E = 25 mm acc. to DIN 43660

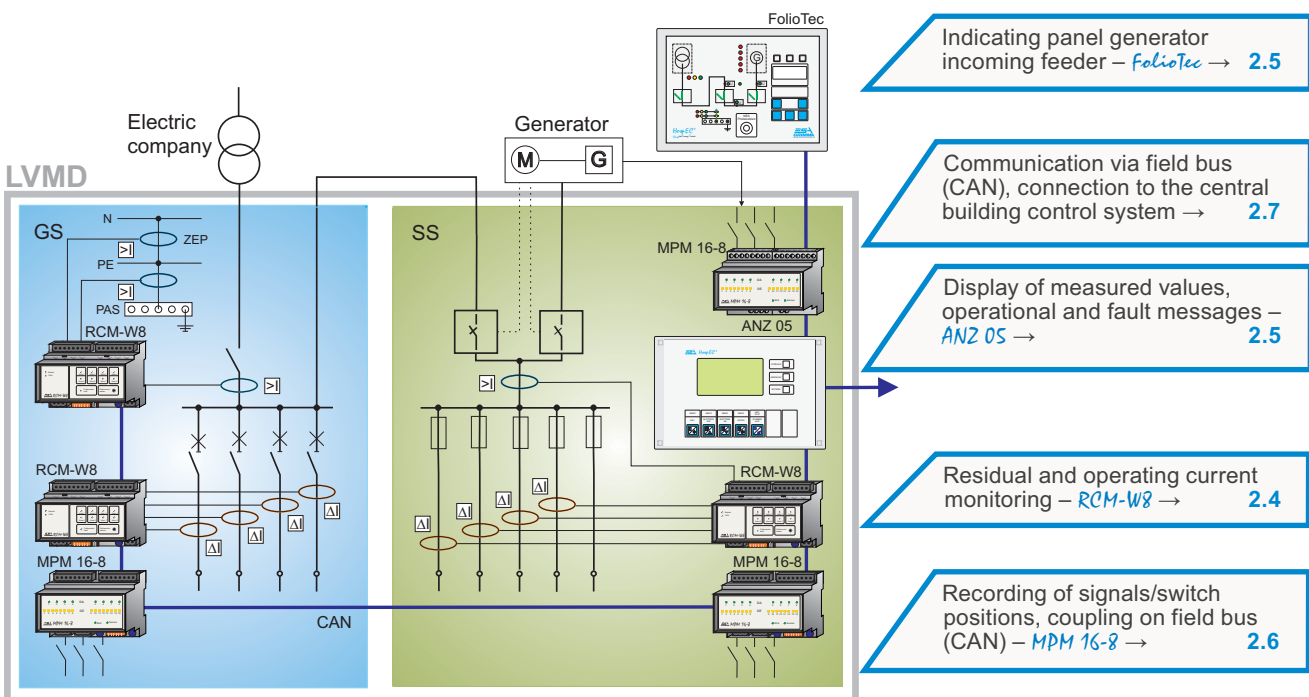

Schematic diagram of a main distribution board

Main building distribution board MBDB

1.2

Requirements

The main building distribution board MBDB is the basis for further configuration of the network structure of the general power supply (GS) and safety power supply (SS) and should be implemented under the following conditions:

- A hospital is composed of several buildings.
- The hospital is in one building, but the cable routing to supply a building section is laid out directly in the ground.
- The hospital consists of one building, but is clearly segmented structurally into several functional areas.
- The main distribution board is installed in a separate building.

The solution

Our main distribution boards consist basically of:

- Incoming/Outgoing feeders general supply (GS)
- Incoming/Outgoing feeders safety power supply (SS)
- Change-over module *UEGL* for switching over to the safety power supply network
- Data connection to the regulation and control system *HoyfEC*® via field bus (CAN)

Project-specific extension with:

- Residual and operational current monitoring devices *RCM* for location and early detection of faulty outgoing feeders or consumers
- Switching of switch positions and coupling in of third-party systems by digital input/output devices *MPM* on the field bus (CAN)
- Display and configuration device *ANZ 05* for display of measured values as well as operational and fault messages

Our products

- Low-voltage switch cabinet (as main building distribution board)
 - Control cabinet system GNS 3.1 – structurally identical with FourLine system made by Striebel & John (based on further developed MNS 3.0 system made by ABB)
 - Control cabinet system Sivacon made by Siemens
 - Automatic change-over module *UEGL* standard
- Regulation and control equipment system *HoyfEC*®
 - Display and configuration unit *ANZ 05*
 - Residual and operational current monitoring device *RCM*
 - Digital input/output devices *MPM*
 - with data interface with standard field bus (CAN)



Switch cabinet, System GNS 3.1



Detail of the MBDB



Assembly of a switch cabinet

Your benefit

- Modular design of the distribution, the change-over module, the function systems and devices
- Optimisation of the maintenance and improvement of the operational and system reliability by residual and operating current monitoring
- Individual planning, project management and execution for every individual situation
- Arc-fault safe insulation between common rail space, device space and connection space
- High operational reliability, personal safety, and availability
- Construction upon request, type-tested according to DIN VDE 0660 Part 500, IEC 60439-1 and DIN EN 60439-1
- Secure separation between the systems (GS and SS)

Technical specifications MBDB

The specifications are the same as for the main distribution board point 1.1

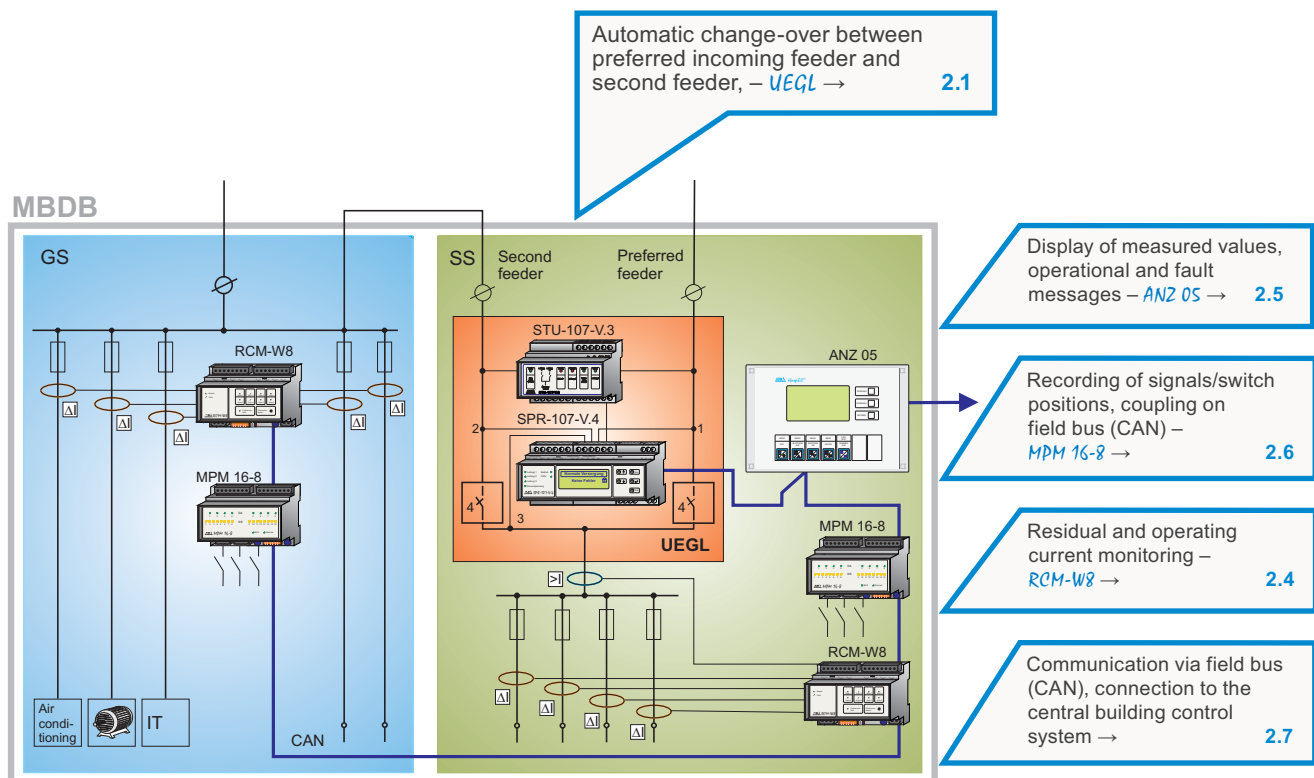

Schematic diagram of a main building distribution board with the change-over module *UEQL*

IT system distribution board *IPS* for areas of group 2

1.3

Requirements

IT system distribution boards are used to supply group 2 medical locations, which must be equipped with an electrical separation safety feature with insulation monitoring and be equipped with insulation fault detection for quick fault rectification in case of an initial fault. For example, you power the following rooms:

- Operating theatres
- Intensive care wards

The solution

IT system distribution boards made by ESA Elektroschaltanlagen Grimma GmbH can be configured with our function system according to project-specific requirements.

Depending on the configuration, the control cabinet system GIV includes these essential components:

- Change-over and monitoring module, type *UEI-710* for
 - Automatic change-over between preferred incoming feeder and second feeder with load module for transformers up to 10 kVA
 - Insulation, load and temperature monitoring
- IT system transformer (3, 15... 10 kVA)
- For optimal heating conditions and protection against accidental contact, separate enclosed area for IT system separating transformers in the distribution system

- Optional: Insulation fault detection system *IFS* for quick fault detection of individual IT system power circuits and for maintenance optimisation
- Data connection to the regulation and control system *HotEC®* via field bus (CAN)

Special features of the complete IT system distribution board *IPS-ICU-710*:

- Change-over and monitoring module, type *UEI-710* with the multifunctional change-over and monitoring device *UEI-710-V.5*
- Standard integrated insulation fault detecting system (*IFS*) up to 30 outgoing feeders
- Complete documentation of faults in a history memory for all operational and fault messages with date and time by the device *UEI-710-V.5*
- Monitoring the recurring checks and triggering a "silent alarm" in case the inspection periods are exceeded and forwarding to BSCS (Building Services Control System) via CAN bus with the device *UEI-710-V.5*
- Small cabinet dimensions with large connection space because of compact construction (H x W x D in mm, 2000 x 350 x 400)

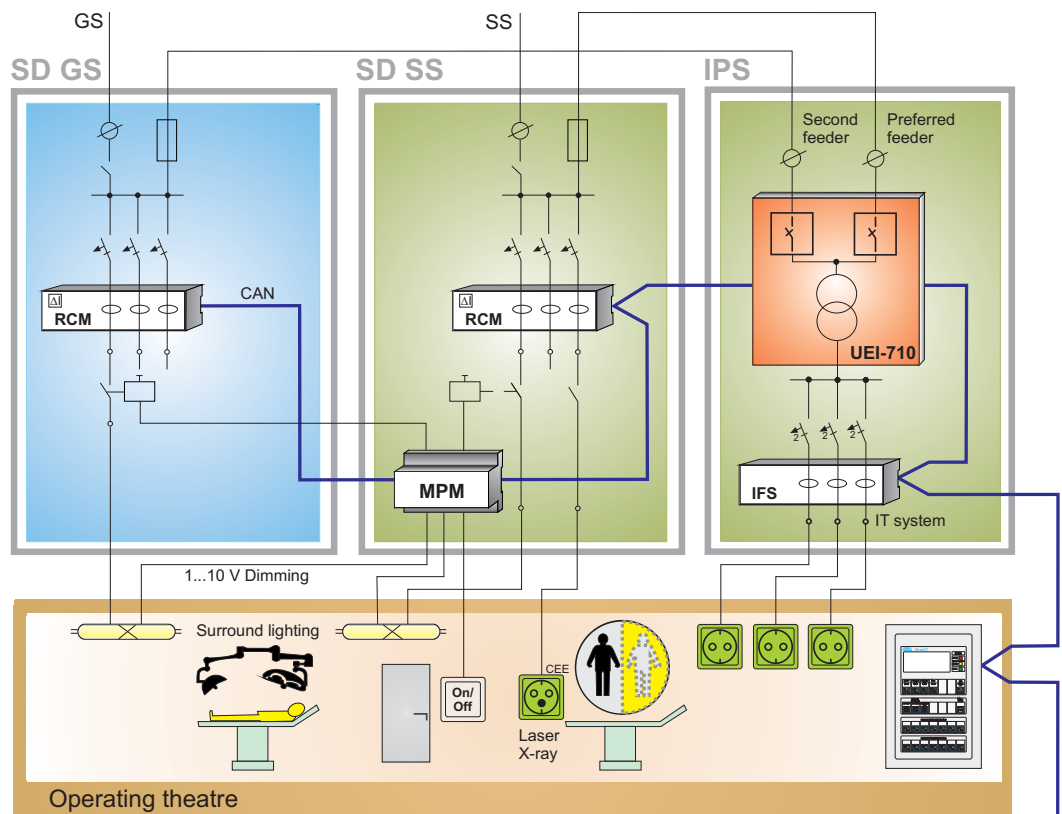

Group 2 (IT system)

Application example: Supply of an operating theatre

Your benefit

- Compact construction of the distribution systems with separating transformer, switching, and IT system monitoring
- Maintenance optimisation through insulation fault detection system
- Separate transformer room for optimal heating conditions
- Low space requirements in the low-voltage central control room due to 2300 mm installation height
- Individual planning, project management and execution for every individual situation
- Adaptable as needed, easily retrofitted and modified
- High operational reliability, personal safety, and availability



Our products

- IT system distribution board (*IPS-OP-710*) with the control cabinet system GIV, with:
 - Change-over and monitoring module *UEI-710* with load module and IT system transformer (3.15...10 kVA)
- IT system distribution board (*IPS-ICU-710*) with the control cabinet system GIV, with:
 - Change-over and monitoring module *UEI-710* with load module and IT system transformer (3.15...10 kVA)
 - Insulation fault detection system *IFS*
- Regulation and control equipment system *HarzEC*[®]
 - Operating and annunciator terminal for IT system *BMTI S*
 - Annunciator and control panel series *FolioTec*
 - Residual and operating current monitoring devices *RCM*
 - Digital input/output devices *MPM*

Note: In Germany, only transformers up to 8 kVA are permitted according to DIN VDE 0100-710:2002-11.

Technical specifications (Control cabinet system GIV)

Technical specifications on the control cabinet system GIV can be found at point 1.4.

IPS-ICU Series 710

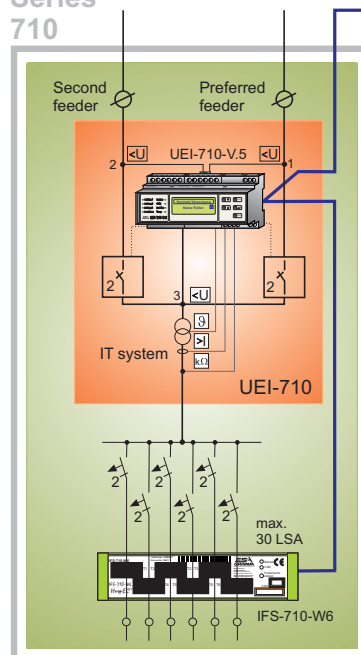

Automatic change-over between preferred incoming feeder and second feeder, monitoring of the control voltage, insulation, load and temperature monitoring, generating the test signal, insulation fault detection – *UEI-710* → **2.2**

Communication via field bus (CAN), connection to the central building control system → **2.7**

IT system transformer

Integrated insulation fault detecting system *IFS* → **2.3**

Subdistributor SD for areas of group 0 and 1 as well as for supplying general areas

1.4

Requirements

Subdistributors are employed to supply medical locations of group 0 and 1 as well as all general areas. This concerns the following rooms, for example:

- Rooms for function diagnosis (CT, MRT, EEG etc.)
- Wards, halls, administration, work and technical rooms
- Laboratories and server rooms (IT)

In hospital environments in particular, a number of special functional conditions must be met, for example:

- Central and local lighting control – even with dimming functions – utilising commercially available installation devices (switches and buttons)
- Monitoring of residual and operational currents for early detection of faults, minimising downtimes, increasing the system reliability and optimisation of the maintenance
- Recording of signals from third-party systems – e.g. medical gases, auxiliary power supplies (APS), heating, ventilation, and air conditioning – and switching onto the field bus for further evaluation (e.g. annunciator and control panels *FolioTec*) up to central building control system

The solution

Our subdistributors are designed specifically for the project and constructed with the GIV switch cabinet system developed by us.

The subdistributors contain, depending on the specific requirements:

- Incoming and outgoing feeders
- Switching and cutout devices
- Residual and operational current monitoring devices *RCM* for location and early detection of faulty outgoing feeders or consumers
- Digital input/output devices *MPM*; e.g. for control of switch positions, detection of signals from third-party systems, for convenient light control – even with dimming functions to conserve energy – and for realising relevant regulation and control functions of a hospital
- Data connection to the regulation and control system *Hot-EC®* via field bus (CAN)

SD GS or SS

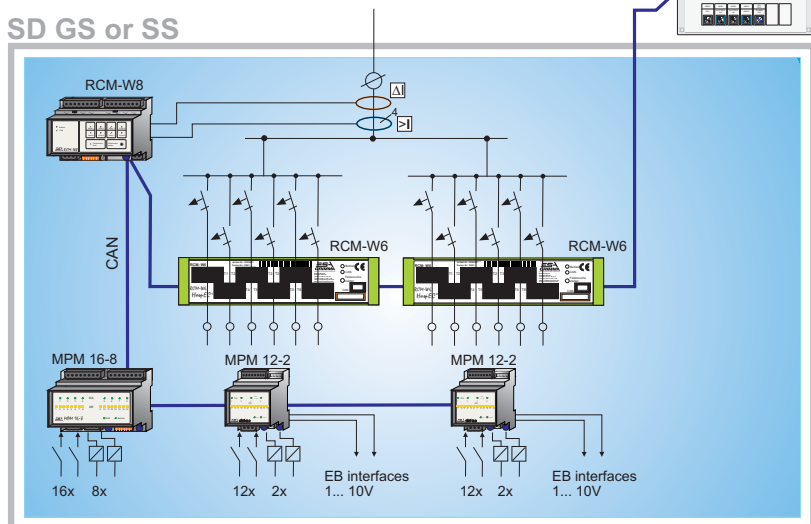

Schematic diagram of a subdistribution

Central lighting control with annunciator and control panel – *FolioTec* → **2.5**

Display of measured values, operational and fault messages – *ANZ 05* → **2.5**

Communication via field bus (CAN), connection to the central building control system → **2.7**

Residual and operating current monitoring – *RCM-W6/RCM-W8* → **2.4**

Recording of signals/switch positions, lighting control, dimming function, coupling on field bus – *MPM 16-8/MPM 12-2/MPM 32-Vario* → **2.6**

Our products

- Subdistributor (SD) with the control cabinet system GIV,

Depending on the project, equipped with:

- Regulation and control equipment system *HotEC®*
 - Residual and operating current monitoring devices *RCM*
 - Digital input/output devices *MPM* with dimming functions
 - Annunciator and control panel series *FabioTec*
 - Display and configuration device *ANZ 05* configuration unit with data interface with standard field bus (CAN)

Your benefit

- Stable, reliable and high-quality switch cabinet system GIV
- Low space requirements in the low-voltage central control room because of 2300 mm installation height
- Switch cabinet completely equipped with all functions typical of hospitals and similar facilities
- Comprehensive regulation and monitoring functions conforming with the project requirements, realisable with devices from the *HotEC®* system – no compatibility problems
- Individual planning, project management and execution for every individual situation
- Adaptable as needed, easily retrofitted and modified
- High operational reliability, personal safety, and availability



Distribution with the control cabinet system GIV (shown with cover open)

Technical specifications of the control cabinet system GIV

Standards/construction	DIN EN 60439-1/3/IEC 60439-1/DIN VDE 0603-1
Rated voltages and rated currents	
Rated surge withstand voltage	6 kV
Overvoltage category	III
Pollution degree	3
Rated operational voltage U_e	690 V AC
Rated insulation voltage U_i	690 V AC
Rated current I_e	Up to 850 A
Rated surge withstand current I_{pk}	Up to 60 kA (30 ms)
Rated short-time withstand current I_{cw}	Up to 20 kA (1 s)
Protection	
Surface protection	Frame – aluminium-zinc coating, cases, doors – steel panel 1.5 mm/ powder-coated
Colour	Powder-coated RAL 7035 light-grey (special colours can be delivered)
Protection class according to DIN EN 60529	IP41
Protection class	I (earthed)
Dimensions	Special sizes upon request
Height (mm with base)	2000, 2300
Width (mm)	350, 600, 850, 1100
Depth (mm)	250, 400

Change-over module *UEQL* for main building distribution boards

2.1

Requirements

Main building distribution boards (main distributor) must feature an automatic change-over module for switching over to the safety power supply network (according to DIN VDE 0100-710 (VDE 0100 Part 710):2002-11, Section 710.537.6.2). Technical requirements are defined in this standard.

Our products

- 4-pin change-over module *UEQL*, type designation: *UEQLxxx/4-V.4* (xxx = rated operational current)

Your benefit

- Standardised and reliable construction
- Simple operation
- Integrated component of the *HofEC®* system
- Communication via CAN bus with all devices from the *HofEC®* system
- Connection options to central building control systems

The solution

In the main building distribution board, our type *UEQL* change-over module reliably realises the switch-over between the preferred incoming feeder and the second feeder. It fulfils all requirements for standardisation, for instance in regards to:

- Voltage monitoring of all active lines (line 1, 2 and outgoing feeder line 3)
- Automatic switching to the second (redundant) feeder in case the voltage of the preferred incoming feeder malfunctions
- Automatic switching back to the preferred feeder
- Configurable switching times
- Control functions with single fault security
- Display/reporting of operational readiness and malfunctions
- Option for function tests on site

Realising the functions by:

- Voltage monitoring device with change-over control *SPR-107-V.4*
- Control voltage change-over device *STU-107-V.3*

optionally expandable with:

- Display and configuration device *ANZ 05* for on-site display of measured values as well as operational and fault messages



UEQL 160/4-V.4



UEQL 80/4-V.4

Technical specifications *UEGL*

Rated operational current	Versions for AC 65/80/100/160/250/400/630 A
Rated operational voltage	AC 230/400 V, 50 Hz
Control voltage	AC 230 V, 50 Hz
Voltage-monitoring (lines 1, 2 and 3) monitored system	1/N AC 0...290 V, 3/N AC 0...500 V, 2 AC 0...500 V-50...60 Hz
Lower triggering value (undervoltage), configurable	150...230 V/260...400 V
Upper triggering value (overvoltage), configurable	230...260 V/400...460 V
Change-over/Pause times, configurable	0...999 s (in 0.5 s steps)
Message outputs	1 exchanger (potential-free)
Display	Operational and fault message via plain text display and LED, via field bus (CAN) at peripheral display devices
Communication interface/protocol	CAN/CAN (2.0) acc. to ISO 11898
Protection class according to DIN EN 60529	IP00
Protection class	I or II

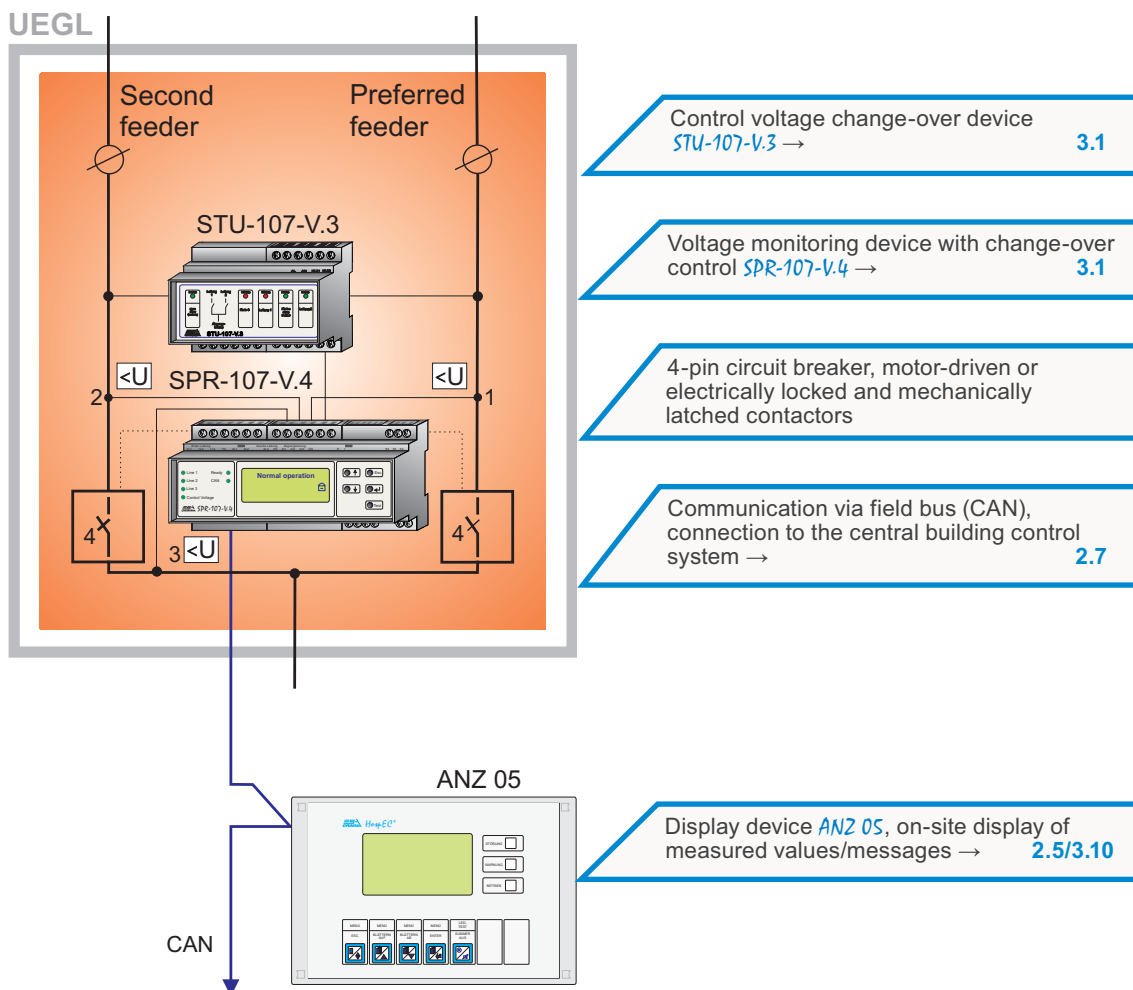

Schematic diagram of change-over module *UEGL*

Change-over and monitoring module *UEI-710, ÜEI-710* for IT system distribution board

2.2

Requirements

Components of IT system distribution boards include switching and monitoring modules for switching between the preferred incoming feeder and the second feeder as well as for insulation, load and temperature monitoring in the IT system.

The solution

Our switching and monitoring modules realise all standardised and functional requirements regarding, for example:

- Voltage monitoring of all active lines (line 1, 2 and outgoing feeder line 3)
- Automatic switching to the second (redundant) feeder in case the voltage of the preferred incoming feeder malfunctions
- Automatic switching back to the preferred feeder
- Configurable switching times
- Control functions with single fault security
- Isolation monitoring in the IT system
- Load and temperature monitoring of the IT system transformer
- Display and reporting of operational readiness and malfunctions
- Option for function tests on site

Realising the functions by:

- Multifunctional change-over and monitoring device *UEI-710-V.5*

For use as on-site display of messages and for initiating test functions:

- Display and configuration device *AN2 0S*
- Operating and report terminal for IT system *BMTI S*
- Annunciator and control panel *FolioTec*

Your benefit

- Standardised and reliable construction
- Simple operation
- Integrated component of the *HayEC®* system
- Communication via CAN bus with all devices from the *HayEC®* system
- Connection options to central building control systems

Our product

- For example, switching and monitoring module *UEI-710*, 2-pin switching and monitoring module with switch control for single-phase networks up to AC 250 V, 50 Hz, insulation monitoring of the IT system, load and temperature monitoring of the IT separating transformer, (integrated insulation fault detecting system optional) – type designation: *UEI-710-6S/2/UEI-710-80/2*

UEI-710

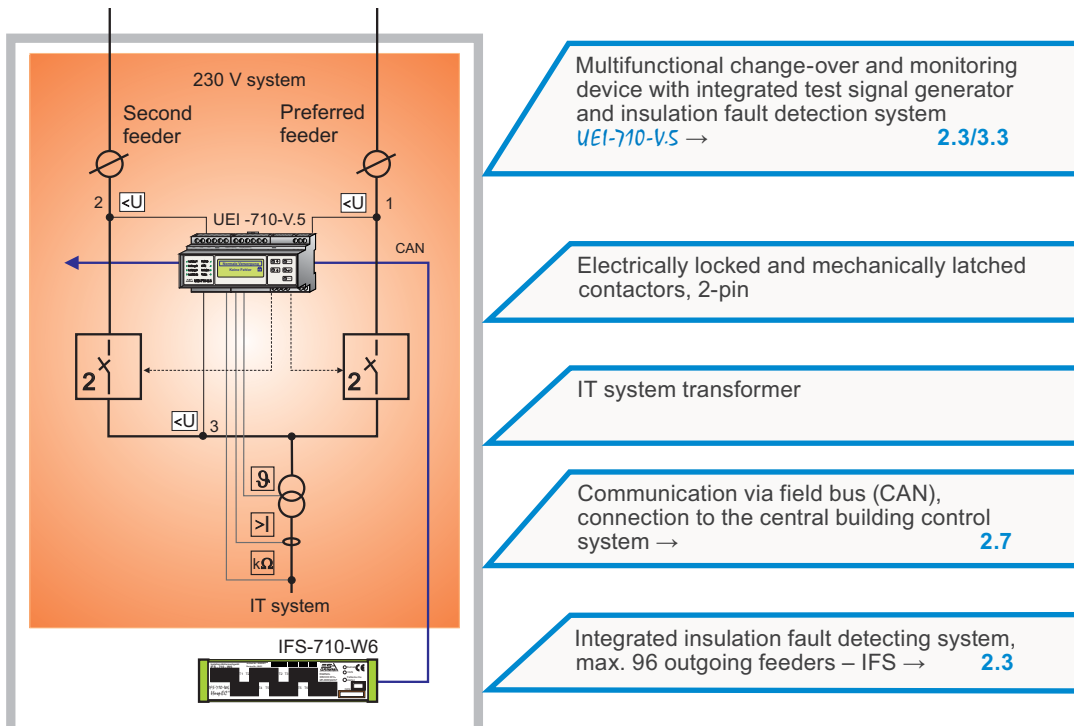

Schematic diagram of change-over and monitoring module *UEI-710--/2-IFS*, with the device *UEI-710-V.5* and integrated insulation fault detecting system, 230 V system

Technical specifications UEI-710

Versions with multifunctional device <i>UEI-710-V.S</i>	<i>UEI-710-6S/2, UEI-710-80/2</i>
Maximum rated output IT system transformers	10 kVA (<i>UEI-710-6S/2</i> up to 6.3 kVA, <i>UEI-710-80/2</i> up to 10 kVA)
Voltage-monitoring (lines 1, 2 and 3) monitored system	1/N AC 0...290 V 50...60 Hz
Lower triggering value (undervoltage), configurable	150...230 V
Upper triggering value (overvoltage), configurable	230...260 V
Change-over/Pause times, configurable	0...20 s (in 0.2 s steps)
Insulation monitoring 230 V AC, configurable	50...250 kΩ
Load current monitoring, configurable	5...50 A
Temperature monitoring (by opener or PTC thermistor)	120 °C
Integrated test signal generator and insulation fault detection system (with <i>IFS-710-W6</i>) – use optional (types <i>UEI-710-../2-IFS</i>)	Maximum 96 channels
Message outputs	1 exchanger (potential-free)
Display	Operational and fault message via plain text display and LED on the device, via field bus (CAN) at peripheral display devices
Communication interface/protocol	CAN/CAN (2.0) acc. to ISO 11898
Protection class according to DIN EN 60529	IP00
Protection class	I or II



Using the device *UEI-710-V.S*, change-over and/or monitoring systems can be designed according to required specifications. During this procedure, the functionality of the previously used devices is adopted.

UEI-710-V.S

Use in change-over and/or monitoring modules

	Device functions			Brief description
	<ul style="list-style-type: none"> Change-over control 1/N AC 230 V Control voltage supply with integrated control voltage switching Insulation, load and temperature monitoring in the AC 230 V IT system Test signal generator (with <i>IFS-710-W6</i> complete insulation fault detection system – <i>IFS</i>) 			<ul style="list-style-type: none"> → Change-over → Control voltage → Insulation monitoring → IFS

Functions	Change-over Control voltage Insulation monitoring IFS	Change-over Control voltage Insulation monitoring	Insulation monitoring IFS	Insulation monitoring
Application with hitherto existing devices	<i>SPR-107-V.4</i> <i>STU-107-V.3</i> <i>ILT-107-V.4</i> <i>IFS-710-PSG</i>	<i>SPR-107-V.4</i> <i>STU-107-V.3</i> <i>ILT-107-V.4</i>	<i>ILT-107-V.4</i> <i>IFS-710-PSG</i>	<i>ILT-107-V.4</i>
Type Change-over and/or monitoring module	<i>UEI-710-../2-IFS</i>	<i>UEI-710-../2</i>	<i>ÜEI-710-IFS</i>	<i>ÜEI-710</i>

Insulation fault detection system *IFS*

2.3

Requirements

Any insulation faults that occur in the IT systems are reported immediately by insulation monitoring devices; the IT system nonetheless continues operation. Quick location and rectification of the insulation fault must be carried out immediately. Without switching off the system or disconnecting consumers, locating and reporting of the concerned outgoing feeder circuit can be conveniently performed by an insulation fault detection system. The maintenance and repair effort should thereby be reduced to a minimum.

The solution

Using our insulation fault detection system (*IFS*), faulty consumer outgoing feeders are detected automatically without switching off the IT system. This is done without measures taken by the technical department or medical personnel.

A message is given with the plain-text display of the cutout designation or specification of the location of the faulty power circuit as well as the determined insulation resistance. Time-consuming manual troubleshooting is thus no longer necessary.

Realisation of the insulation fault detection system with:

- Multifunctional change-over and monitoring device *UEI-710-V.5*
- Insulation fault detection devices *IFS-710-W6*

or with:

- Insulation, load and temperature monitoring device *ILT-107-V.4*
- Test signal generator for insulation fault detection *IFS-710-PSG*
- Insulation fault detection devices *IFS-710-W6*

Display of signals are done for example on the:

- Multifunctional change-over and monitoring device *UEI-710-V.5*
- Insulation, load and temperature monitoring device *ILT-107-V.4*
- Operating and report terminal for IT systems *BMTI 5*
- Display and configuration device *ANZ 05*
- Annunciator and control panel *FolioTec*



IFS-710-W6

Principle sequence of an insulation fault detection

The device with insulation monitoring function (*UEI-710-V.5/ILT-107-V.4*) constantly identifies and monitors the insulation resistance in the IT system. If the insulation resistance drops below a specified value, then the search process is started by the test signal generator (*IFS-710-PSG/integrated in the UEI-710-V.5*).

This feeds a test signal (limited to 1 mA) into the IT system. The test signal is detected by the insulation fault detection device (*IFS-710-W6*) by its integrated converter (per outgoing feeder circuit) – the faulty circuit is thus isolated. The test signal generator evaluates the fault detection and transfers the evaluation on the field bus (CAN).

Corresponding messages are now generated by the insulation monitoring device and peripheral display devices.

The operator receives detailed information on the faulty power circuit; messages can be saved for future evaluations.

Communication between all devices occurs over the standard field bus (CAN).



Detail of an IT system distribution *IPS-ICU-710* with Insulation fault detection system (*IFS*)

Your benefit

- Quick, automatic location of faulty power circuit during operation
- No user intervention necessary
- No time-consuming manual troubleshooting
- Optimisation of maintenance
- Improved system reliability
- Reporting and storage of faults
- Integrated component of the *HexEC*® system
- Communication via CAN bus with all devices from the *HexEC*® system
- Connection options to central building control systems

Our products

- Multifunctional change-over and monitoring device *UEI-710-V.5*
- Insulation, load and temperature monitoring device *ILT-107-V.4*
- Test signal generator for insulation fault detection *IFS-710-PSG*
- Insulation fault detection device *IFS-710-W6*
- Control equipment system *HexEC*®
 - Operating and report terminal for IT systems *BMTI 5*
 - Display and configuration device *ANZ 05*
 - Annunciator and control panel *FolioTec* with data interface with standard field bus (CAN)

Technical specifications IFS

Number of measuring channels per <i>IFS-710-W6</i>	6 (measurement converter integrated)
Number of measurement channels per IT system	Maximum 132 (96 with <i>UEI-710-V.5</i>)
Fault detection time	About 3 sec.
Test signal limited to	Maximum 1 mA
Measurement value logging	Parallel (no multiplex process)
Communication interface/protocol	CAN/CAN (2.0) acc. to ISO 11898
Messages on the <i>ILT-107-V.4/UEI-710-V.5</i>	Cutout designation of the location of the faulty power circuit, insulation resistance
Messages to peripheral display devices (<i>BMTI 5, ANZ 05, FolioTec</i>)	Acoustic message, insulation resistance, freely configurable texts on site and designation of faulty power circuits

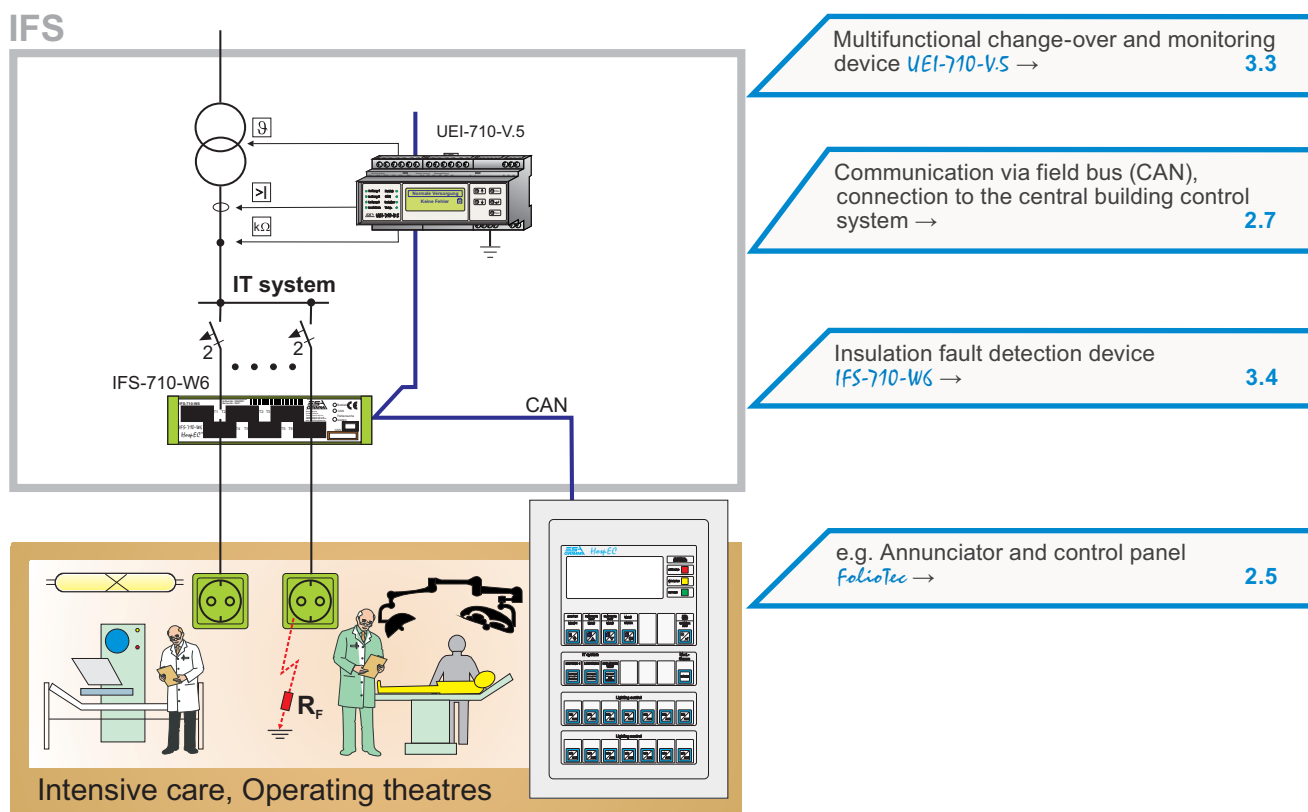

Schematic diagram of insulation fault detection system IFS with UEI-710-V.5

Residual and operational current monitoring system *RCM*

2.4

Requirements

Detecting faults in time, reporting them and thereby avoiding shutdowns is an important goal of system operators who set high standards regarding availability and operational reliability of the electrotechnical equipment.

To accomplish this goal, it is typically necessary to monitor, evaluate and report on gradual increases of residual currents (caused, for example, by faulty insulation) and excessive operational currents of system subassemblies or consumers before these lead to a malfunction!

The solution

Using our residual and operational current monitoring system, you can avoid disturbances in the power supply with early warnings, also improving the system and fire protection.

During residual current monitoring, the fault currents flowing to earth or other paths are detected according to IEC 60755 type A. These are:

- in the incoming feeder
- in the outgoing feeders (consumers and systems)
- straying currents in TN-S systems (PEN and N-lines)
- and at central earthing points

Your benefit

- Locating faults without shutting down.
- System faults are signalled by early warnings.
- Avoidance of costly or dangerous system malfunctions – the availability of the systems is increased.
- Reduced effort for troubleshooting and repair by locating individual faulty outgoing feeders or consumers.
- Overloading of the N-lines and critical fault currents is detected early, thereby achieving greater fire protection.
- By configuring the system when it is new, all changes to the system status as of commissioning can be recognised.

Messages are sent to peripheral display devices via the standard field bus (CAN) and are available also for evaluation and regulation purposes. The data coupling to vendors' systems is realised, for instance, via digital input/output devices of the *MPM* (binary) series or via gateways to protocols such as LON® or Modbus. Connecting to the central building control system is possible.

Input/output devices of the *MPM* series connected to the CAN bus can send the system, for instance, a binary signal indicating that a threshold has been exceeded, with respect to any monitoring channel, for further regulation purposes.



Residual and operating current monitoring in the incoming feeder

RCM

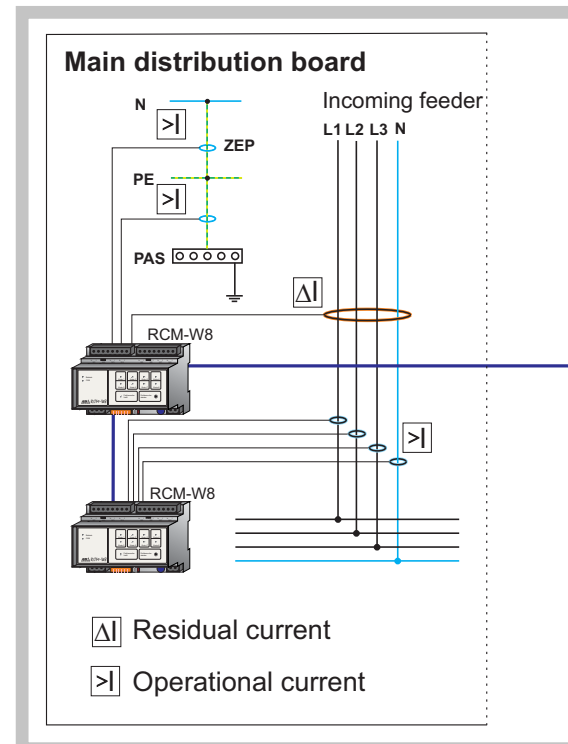

Schematic diagram of residual and operational current monitoring system *RCM*

Our products

- Residual current monitoring device [RCM-W6](#)
 - Residual and operational current monitoring device [RCM-W8](#)
 - Regulation and control equipment system [HospEC®](#)
 - Display and configuration device [ANZ 05](#)
 - Annunciator and control panel [FolioTec](#)
 - Digital input/output devices [MPM](#)
- with data interface with standard field bus (CAN)

Technical specifications [RCM](#)

	RCM-W6	RCM-W8
Number of measuring channels	6 (converter integrated in device)	8 (converter can be connected to device)
Measurement value logging	Parallel measurement value logging and processing, true root mean squared	
Evaluation	Residual currents	Residual and operating current (channels freely configurable)
Evaluation range of residual current	10...1000 mA	
Evaluation range of operational current	–	1...4000 A (depends on converter)
Measurement converter	internal	external
Converter rated voltage	AC 20...720 V	
Converter rated frequency	50...60 Hz	
Converter rated current	50 A	1...4000 A (depends on type)
Configurable values per channel		
Warning and triggering thresholds	Freely configurable	
Hysteresis for triggering thresholds	Freely configurable	
Time delay for messages	Freely configurable	
Window function during operational current measurement	–	Freely configurable
Message outputs	–	1 exchanger (potential-free)
Display	LED on the device, external by field bus (CAN) e.g. on the ANZ 05	
Communication interface/protocol	CAN/CAN (2.0) acc. to ISO 11898	
Configuration	PC-Software " HospEC® configurator" (via USB-CAN adapter), display and configuration device ANZ 05 (via field bus CAN)	

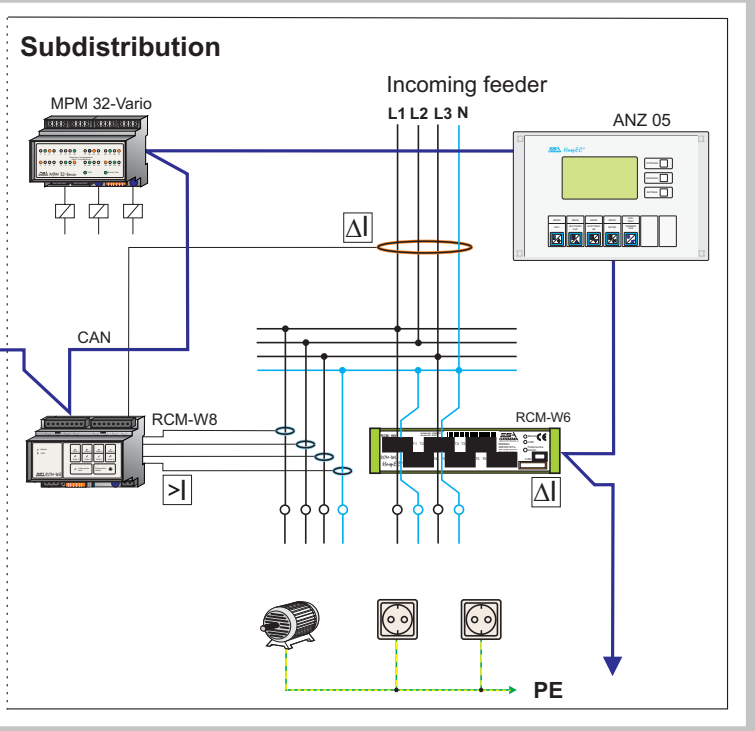

- Decoupling of channel-oriented signals for control purposes – [MPM 16-8, MPM 32-Vario](#) → **2.6**
- Display and configuration device [ANZ 05](#) → **2.5/3.10**
- Residual current monitoring device [RCM-W6](#) → **3.6**
- Residual and operational current monitoring device [RCM-W8](#) → **3.7**
- Communication via field bus (CAN), Connection to central building control systems → **2.7**

Display and operating systems *FolioTec*, *BMTI 5*, *ANZ 05*

2.5

Requirements

Information about the entire system – from the technical medical issues to the facility management issues – need to be provided to the operator, centrally and locally as well as assigned to individual areas. Likewise, control activities are carried out from these locations. Since the personnel, particularly in hospitals, constantly needs to manage a flood of information, these display and control system must conform to the principle of “display only as much as necessary.” If actions need to be taken, it must be possible to execute these actions quickly, intuitively and they must be recognisable at a glance.

The solution

With our display and control devices, we provide the user with a system that realises all necessary control and operational functions and also conforms to requirements typical of hospital:

- Easy handling using a small number of operating buttons and a simple menu structure

Your benefit

- Specially designed for use in medical locations
- Laid out for quick reception of all necessary messages
- Simple, clearly arranged and intuitive controls
- Transparent buttons and display elements, backlit by multicoloured LEDs
- Closed, multilayered and permanently stable foil surface, resistant against cleaning and disinfectant agents, UV-proof
- High protection class of the operating interfaces (IP54)
- Communication via standard field bus (CAN) with all devices from the *HayEC®* system
- Unproblematic integration in the central building control system
- Connection option of regulation and control functions also for third-party systems
- General processing of the system's data, no commitment to predefined warning and operational messages

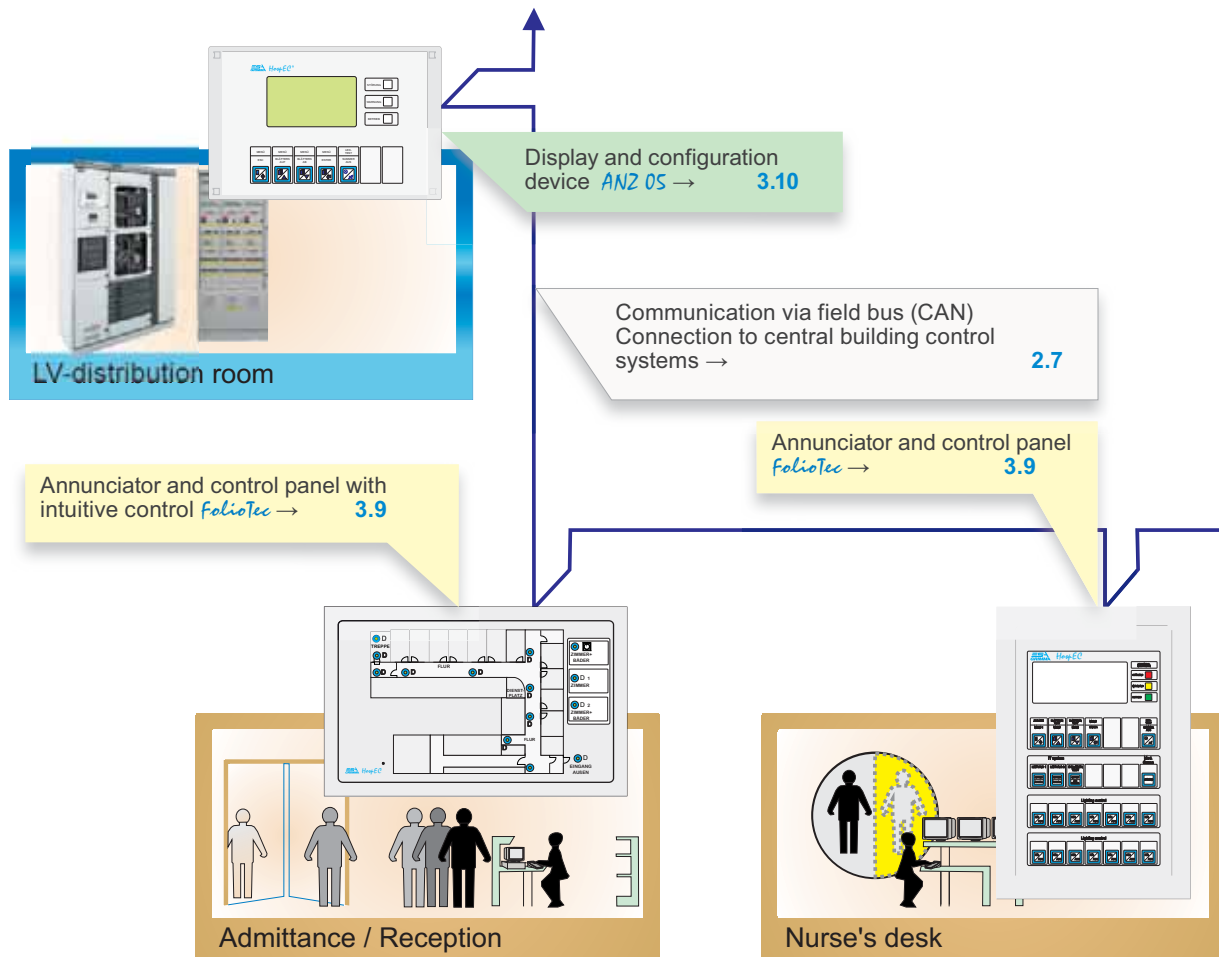

HayEC® Display and operating system in the hospital

Our products

AN2 OS – large display

As display and configuration device, e.g. for displaying messages of all devices from the *HotEC*® system, for messages from third-party systems as well as for displaying measured values and configuring residual and operational current monitoring devices *RCM*.

BMTI S – small display

Operating and annunciator terminal, e.g. for displaying operational and fault messages of the IT system in medical locations according to DIN VDE 0100-710 (VDE 0100 Part 710):2002-11.

FolioTec – large display with additional functions

Series of annunciator and control panels, for example for display operational and fault messages of IT systems, change-over controllers, for display of measured values and messages from all devices from the *HotEC*® system, for messages from third-party components, for operating table control, integration of voice communication, lighting control, sun-blind control, mapping and control of further processes of the entire system.

Application area	Switch cabinet	Nurse's desk Intensive care Anaesthesia/ recovery rooms	Operating theatres Nurse's desk Admittance/Reception
Functionality	Displays Configuration Testing	Displays Configuration Testing	Displays Testing Controlling and switching Operating table control Built-in loading station Integration telephone and clocks Air conditioning control Lighting systems control
Utilising the following devices	AN2 OS, BMTI S	AN2 OS, BMTI S	Panels from the series <i>FolioTec</i>

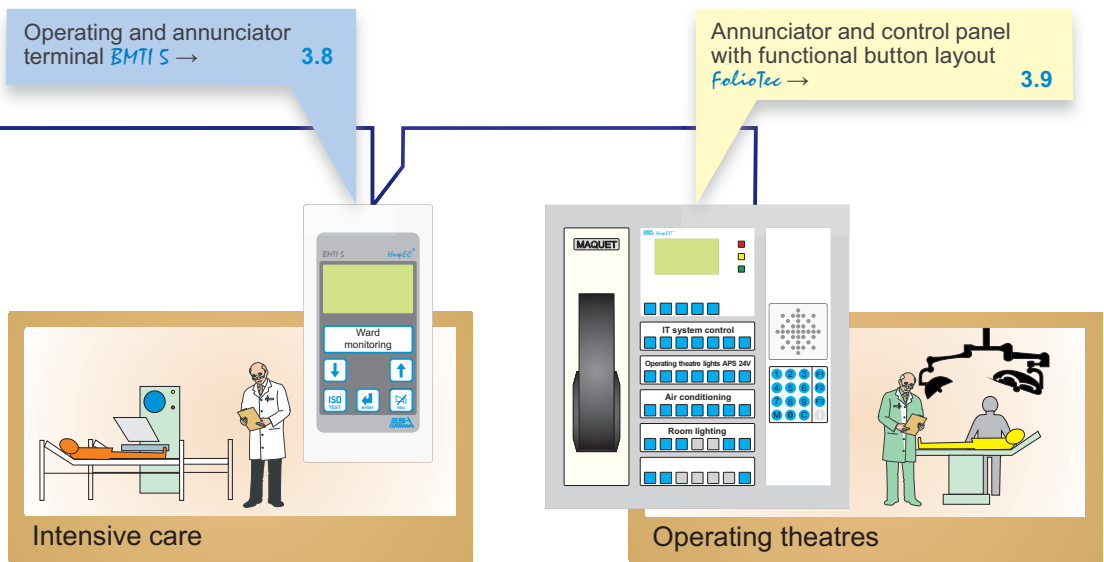

Lighting control/Linking to third-party systems with digital input/output devices *MPM*

2.6

Requirements

Taking the diverse requirements into account, lighting control for all areas should be designed to be simple and yet convenient. It is an advantage when “normal” switches and buttons can be used as installation devices.

Links from central or on-site operational functions should be taken into account and realised economically along with functions depending on daylight, time and presence as well as special requirements for the lighting circuit supply from the GS and SS system and user-friendly control of the surround lighting in operating theatres.

Beyond that, there are a number of regulation and monitoring tasks. Signals from the building need to be evaluated, linked together, displayed and provided for various location for incorporation into further process controls or for display.

The solution

Using our bus-capable, digital inputs and output devices with independent logic function of the *MPM* series, you can realise all lighting controls and other regulation and monitoring tasks with a minimum of expense.

With their functionality and compliance with required security specifications (“single fault security”), they replace conventional, expensive technology, in particular when employed in medical locations such as hospitals.

Your benefit

- Control functions for safety and general lighting (SS and GS circuits)
- Simple and convenient control for operating theatre surround lighting
- Low-cost realisation of multifunctional light control – also with dimming functions
- Entry switches with standard installation buttons and switches possible
- Integration of signals of the entire building in the existing bus system
- Safety functions by definable initial conditions after reset – for example voltage interruption (low, high, last status before reset)
- High flexibility during planning and subsequent function modification by simple reprogramming of the logic functions – no wiring or installation changes.

Basic functions

The devices register any digital signals with their physical inputs (potential-free or non-floating). Logical inputs are registered as well. These are signals that are found on the field bus (CAN). They come from other field bus devices, such as additional devices of the *MPM* series, annunciator and control panels, as well as from all other ESA bus devices. All signals can be linked together logically and be made available at the physical switch outputs for evaluation and regulation purposes.

The statuses of the physical inputs and outputs are constantly transferred to the field bus and are available thereby for evaluation by other devices.

The *MPM 12-2* also features 2 interfaces for regulating electronic ballasts (EB) with 1...10 V interface and convenient dimming function. On the *MPM 32-Vario*, the 32 channels can be freely used as inputs or outputs upon configuration.

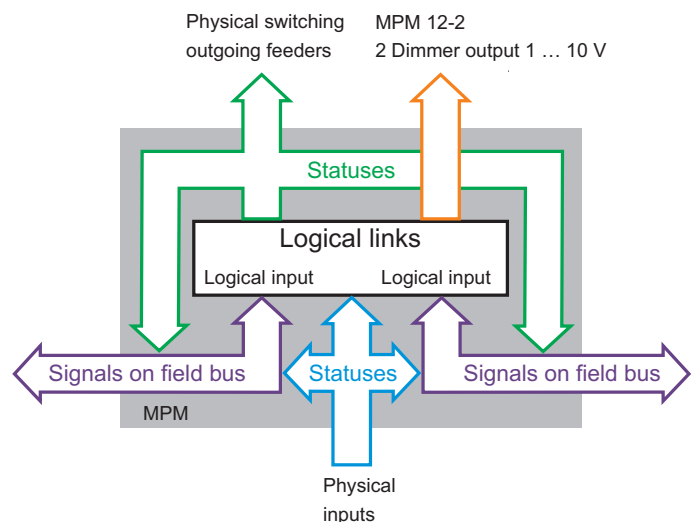

Simplified functional scheme *MPM 12-2/16-8/32-Vario*

- The devices can be run independently without bus connection (stand-alone); safety functions when the bus is switched off.
- Reduced fire risk by omitting control cables
- Reduced installation costs – shorter mounting times

A significant advantage when used in medical locations:

- Highest security due to independent local logic functions of each device and specified switch functions in case the monitored bus devices fail or the field bus malfunctions. This is ensured by the “single fault security” required according to DIN VDE 0100-710 (VDE 0100 Part 710):2002-11.

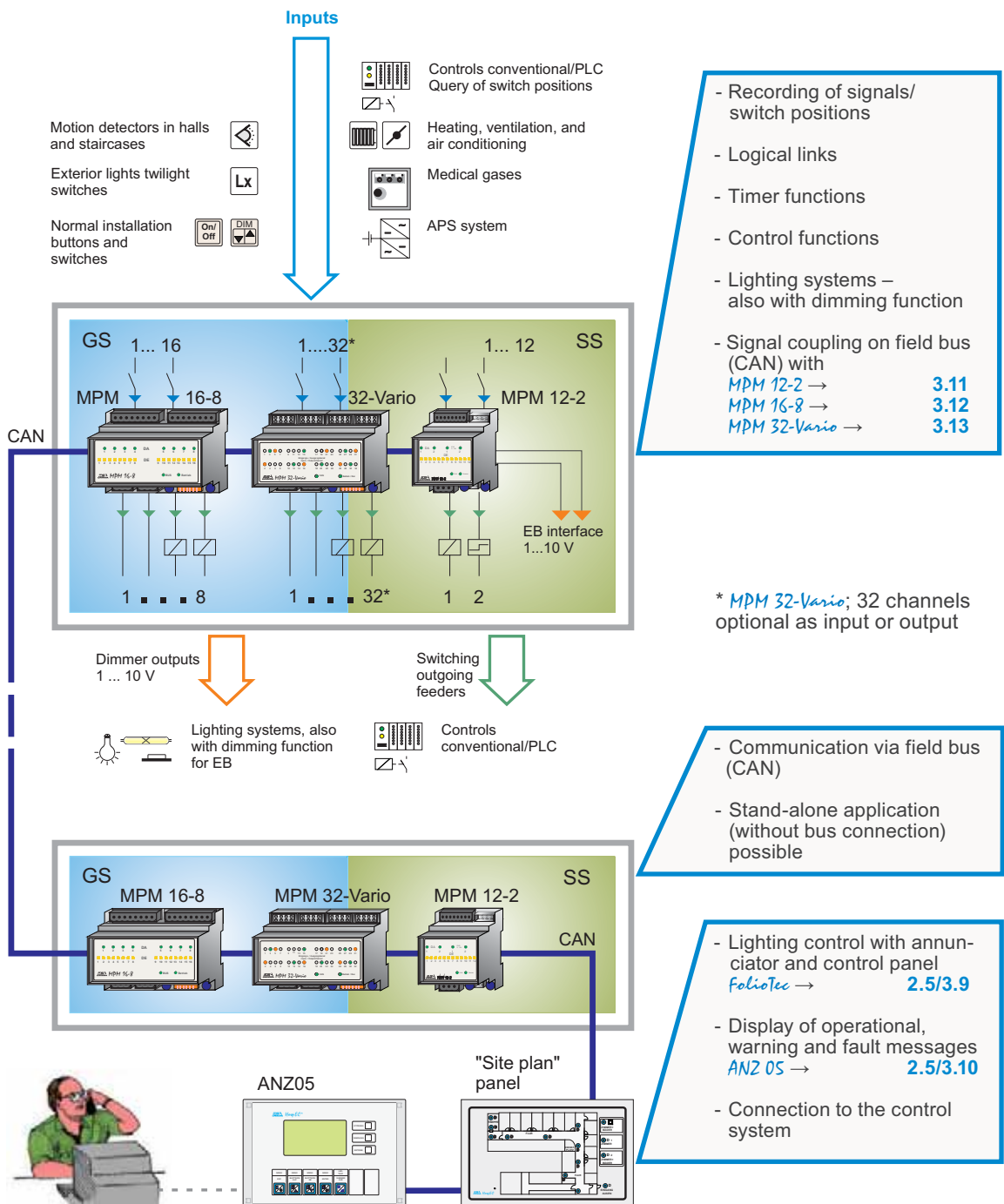

Connection options of the MPM

Lighting control/Linking to third-party systems with digital input/output modules *MPM*

2.6

Our products

- Digital I/O-device with independent logic function *MPM 16-8*
- Digital I/O-device with independent logic function and variable utilisation of the channels as input or output *MPM 32-Vario*
- Digital I/O-device with independent logic function and dimming control for EB *MPM 12-2*
- Regulation and control equipment system *Hosp-EC®*
 - Annunciator and control panel *FolioTec*
 - Display and configuration device *AN2 OS* with data interface with standard field bus (CAN)

Example:

Surround lighting in the operating theatre

Your requirements ...

- Simple and clearly laid out control
- Lighting power supply via 2 separate circuits (general supply – GS, safety power supply – SS)
- Joint or individual switching of both circuits by operating panel in the operating theatre
- Light scenario control (memory function), which can be saved by the user
- Lighting dimming by EB with standard interface 1...10 V
- Joint or individual dimming of both circuits (GS and SS)
- “Custodian function” for external switch (switch next to door)
- Soft-on and soft-off effect of the individual circuits (switching on and pleasant dimming until full light strength or maximum value, converse function during switching off)
- Switching on the safety lighting during network backup operation (only SS), depending on the switch position of the light circuits before network interruption (If only GS circuit was in operation before network failure, then the SS circuit should go into operation automatically.)
- If dimming was down, then the SS circuit should be set to 100% automatically in case of GS malfunction.

... are realised by us:

All ESA annunciator and control panels of the *FolioTec* series in operation theatres are equipped (standard) with a control for two separate light groups. These are fed from separate supply areas (each 1 x general supply – GS, and 1 x safety power supply – SS).

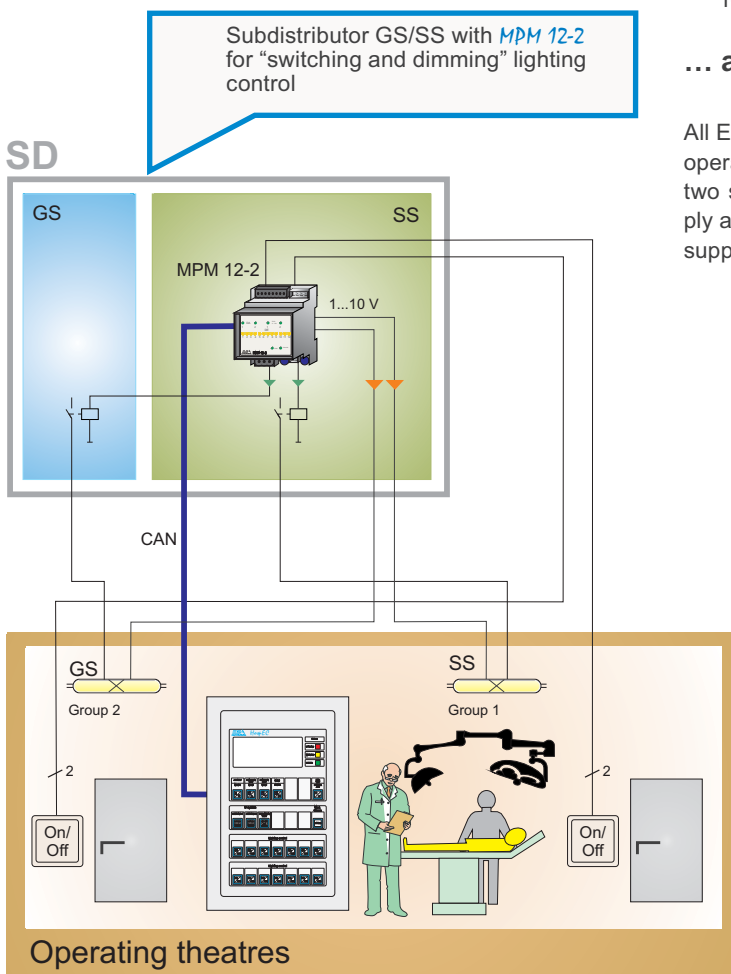

Subdistributor GS/SS with *MPM 12-2* for “switching and dimming” lighting control

Communication *MPM 12-2*/operating theatre panel via field bus (CAN)

- Surround lighting, dimmable with EB
- Lighting control on the operating theatre signal a. operating panel *FolioTec* → **3.9**
- “Custodian button” next to door as normal button

Standard version for surround lighting in operating theatres

Control bar for room lighting in the operating theatre – annunciator and control panel

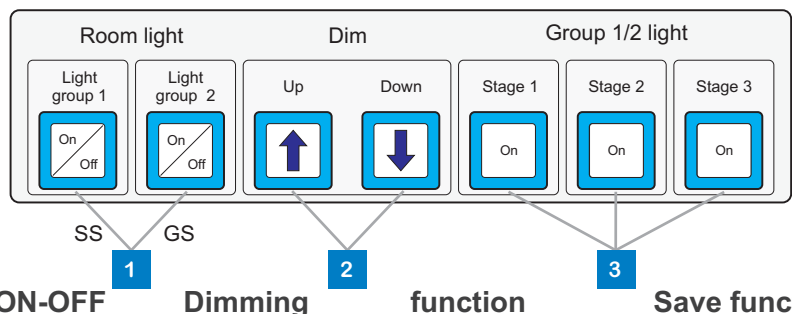

To switch the groups on and off. If the group is switched on, this is indicated by the green light of the respective button.

To dim the groups. This function acts on both light groups simultaneously and parallel, also if, for example, light group 2 is not in operation. If this group is switched on as well then, the preset dimming value is also set for this group.

To invoke saved dimming values (light intensity values) – acts on both groups; 3 presets are saved by default. A simple routine permits changes by the user.

Technical specifications MPM

	MPM 12-2 with dimming function	MPM 16-8	MPM 32-Vario
Physical inputs	12	16 (2 groups of 8)	32* (4 groups of 8)
Type of inputs	Potential-free or non-floating (max. 24 V DC)		Non-floating (max. 24 V DC)
Physical outputs	2 (Relay contacts AC 230 V/1500 VA) 2 digital potentiometer for controlling dimmable EB with 1...10 V interface	8 (relay contacts AC 230 V/1500 VA)	32* Open collector (24 V DC, 350 mA, short circuit-proof) * (32 channels optionally configurable as inputs or outputs)
Functions	<ul style="list-style-type: none"> - Reading of relay messages in the standard field bus (CAN) - Light control and further control functions by installation buttons/switches or operating panels - Reading and processing of messages from the field bus - Output of messages/commands at switch outputs and on the field bus <p>Additionally on MPM 12-2:</p> <ul style="list-style-type: none"> • Light scenario control (max. 2 circuits with 4 scenarios each), which can be saved by the user • Extensive dimming functions (e.g. joint or individual dimming of both circuits single or double switch versions, soft-on and soft-off effect of the circuits) • “Custodian function” for on-site switch can be added • Switching on the safety lighting during network backup operation (only SS), depending on the switch position of the light circuits before network interruption. (If only GS circuit was in operation before network failure, then the SS circuit should go into operation automatically.) To do so, the device communicates with the responsible voltage monitoring. • If dimming was down, then the SS circuit will be set to 100% automatically in case of GS malfunction. 		
Software functions	<ul style="list-style-type: none"> - Free assignment of input/output channels (operational/warning/fault messages) - Defined initial conditions after reset (low, high, last status before reset) - Logical links of variables (physical inputs of the device and status messages from the field bus) - Control functions for safety and general lighting (SS and GS circuits) - 120 logical inputs (messages from the field bus) can be processed - Logic operands AND, OR, XOR, NOT – up to 20 operands per logic formula, 5 timer operands, reset and output operand - Stand-alone operation (without bus connection) - Monitoring of other field bus device (sign of life) - 32 Switch clock channels with integrated real time clock (RTC) 		
Configuration	PC-Software “HospTEC® configurator” (via USB-CAN adapter), MPM 12-2: For stand-alone application also by DIP switch		
Displays	with LED: Status displays of the inputs/outputs/operation/bus		
Communication interface	CAN/protocol CAN (2.0) acc. to ISO 11898		

Standard field bus CAN

2.7

The requirements

All devices used by the regulation and control system *HospEC®* need to communicate with each other.

For example, messages from change-over and monitoring modules need to be sent through IT system distribution boards to on-site display and operating systems such as control and annunciator terminals (*BMTI 5*) or annunciator and control panels (series *FolioTec*) in operation theatres or intensive care wards.

Measured values, control commands, error and fault messages as well as other signals from ESA devices need to be communicated. Furthermore, the communication system has to be capable of incorporating signals from other components.

Focus is placed on a simple yet reliable transmission process, as utmost requirements are put on reliability, in particular in medical facilities.

Our solution

The standard field bus CAN (Controller Area Network) is used in the *HospEC®* system as a communication system.

The CAN bus, as serial multi-master bus system, ensures a reliable function and a high transmission reliability even under difficult ambient conditions. By using several safety mechanisms, the possible fault risk is exceedingly small.

Due to its outstanding feature – high transmission reliability – it is increasingly employed for applications in highly security-critical areas.

Function principle and bus topology

The basic principle: all bus devices can operate with essentially equal rights in the bus. The CAN controllers of the individual devices control the access to the bus, send and receive the data, evaluate faults and initiate corrections. Messages from safety relevant devices are transmitted and evaluated with a higher priority.

There is no “main controller” that could fail and cause the entire system to crash. That is why it is called a “multi-master system”. This results, for example, in a reliably high level of availability of this bus system.

The bus topology for individual bus segments is essentially linear. Bus segments can be connected by appropriate micro controllers, for example in panels. Gateways serve to connect other bus systems (e.g. LON®) to the CAN bus and to extend the system.

The linking of the *HospEC®* bus systems (CAN) to other systems is ensured. For example, protocols such as LON®, EIB, or Modbus® can be integrated and processed.

The transmission of signals from the CAN bus into these bus systems is also feasible. Furthermore, binary signals (e.g. potential-free contacts) can be linked in, output and also processed.

The possibilities listed above ensure a high degree of compatibility with all third-party components.

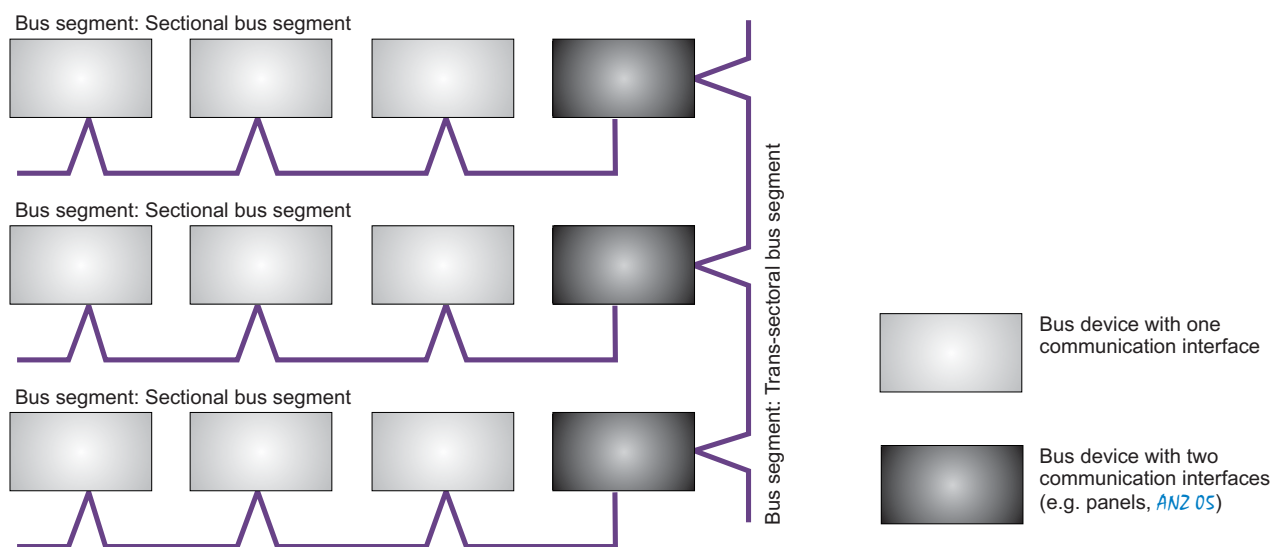

Principle bus topology

Special security aspects in the HospEC® system

Even the most reliable equipment can, under certain conditions, break down; with possible contribution by gross negligence by humans – this does (unfortunately) happen in daily use. We take this fact into account with a series of special measures:

Your benefit

- Future-proof standard field bus system with CAN 2.0 protocol (according to ISO 11898)
- High transmission reliability – even under difficult ambient conditions
- Simple and clearly laid out bus structure
- Maximum extension of a bus segment up to 2500 m
- Use of standard cable for the data lines (J-Y(ST)Y 4 x 2 x 0.8 Lg acc. to VDE 0815 with standardised colour coding of the wire pairs)
- Integration of binary signals and protocols such as LON®, EIB or Modbus possible

For example ...

- Change-over modules between the GS and SS power supply systems continue to function reliably even if there is a bus fault. Their control and monitoring devices then send error messages via message relays.
 - The power supply of the bus and the CAN controller of all bus devices is provided by parallel-switching power supply packs (24 V DC) from the safety power supply network (SS).
 - To further increase the reliability, independently functioning bus segments are created, for instance. These are, for example, the switching and monitoring modules belonging to an operating theatre, corresponding display and control systems as well as other bus devices associated to this section.
 - These “sectional bus segments” function self-sufficiently; should any other bus segment break down, all other sections continue to function reliably.
 - The single fault security required according to DIN VDE 0100-710 (VDE 0100 Part 710):2002-11 is ensured.
-
- The digital input/output devices **MPM** can detect malfunctions by bus devices (time-out function) and emit messages via potential-free contacts in case “signs of life” are missing.

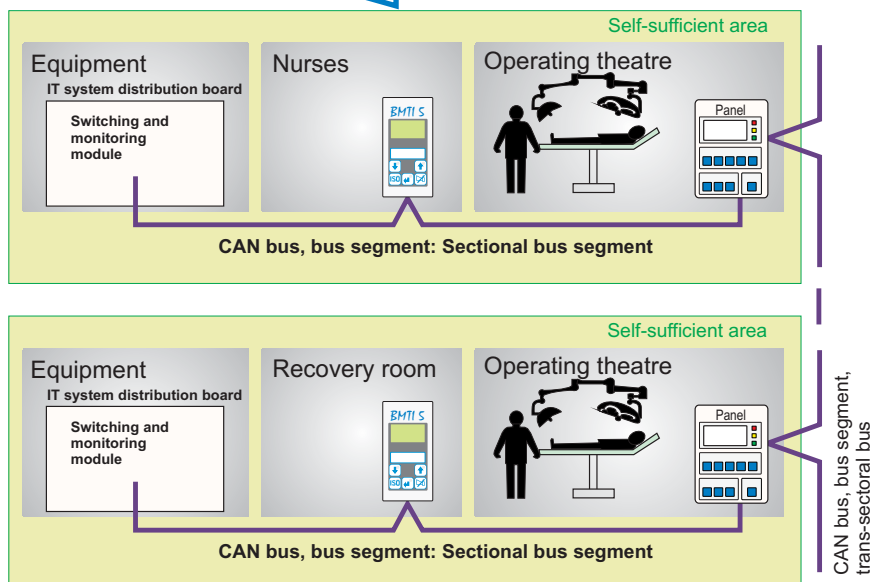

Schematics of the self-sufficient areas

Standard field bus CAN

The CAN bus in the *HayEC®* system

The bus topology for individual bus segment is essentially linear. Bus segments can be connected by appropriate micro controllers, for example in panels.

Termination:

The data carrying lines in the bus (CAN-Low/CAN-High) need to be connected with a resistor (120 Ω, 0.25 W) at the beginning and the end of every bus segment to avoid reflections.

Each distribution system is equipped with an XCAN-terminal adapter. It creates a defined transfer point for the (external) bus and the bus section within a distribution system. Power supply packs can be connected to these terminal adapters.

Furthermore, it features a switchable resistor for the termination.

Panels are also internally equipped with a clamp adaptor for the same purpose.

Power supply packs, which can be switched in parallel, provide the supply voltage of 24 V DC for the bus and its devices in distribution. In case further devices in the same bus segment need a power supply through the CAN bus (e.g. *BMTI 5*), then additional power supply packs can feed into the distributions through the XCAN-terminal adapter. Panels have their own power supply packs.

2.7

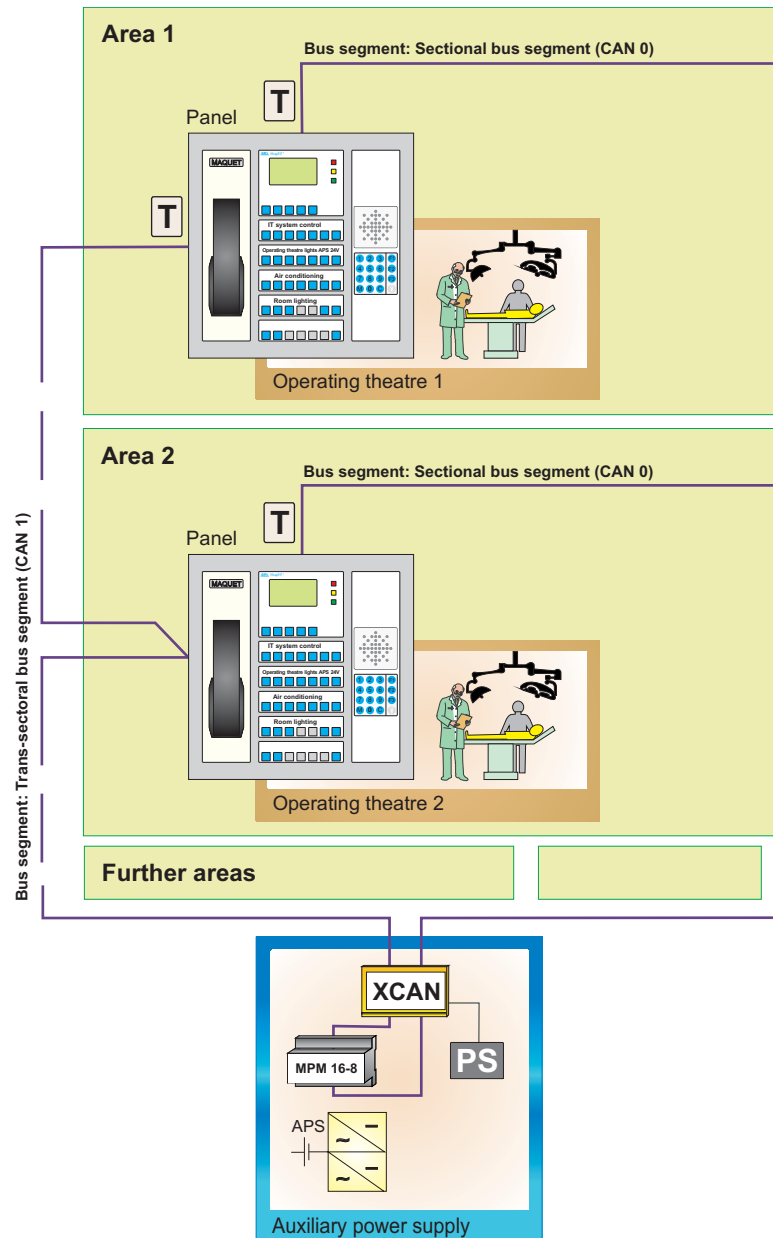

Example for bus structure

Technical specifications

Protocol	CAN (2.0) acc. to ISO 11898
Supply voltage	DC 24 V
Maximum bus length	2500 m (per bus segment)
Cable type	J-Y(St)Y 4 x 2 x 0.8 Lg (VDE 0815) with standardised colour coding of the wire pairs
Device per bus segment	Max. 110
Possible protocol/signal couplings	LON®, EIB, Modbus, RS232, RS485, TCP/IP, binary

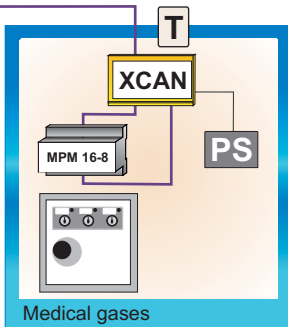
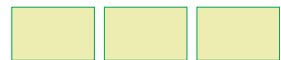
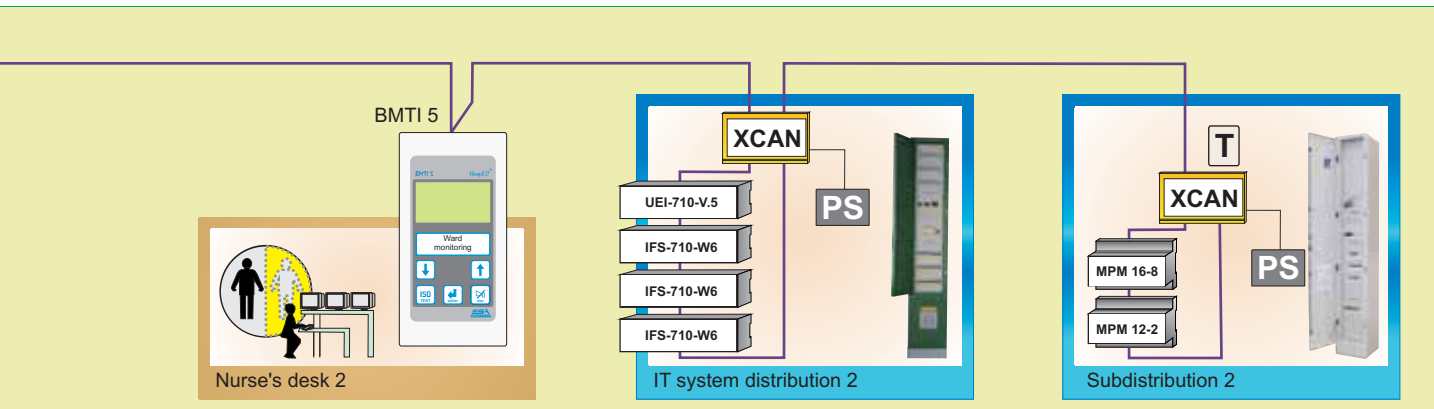
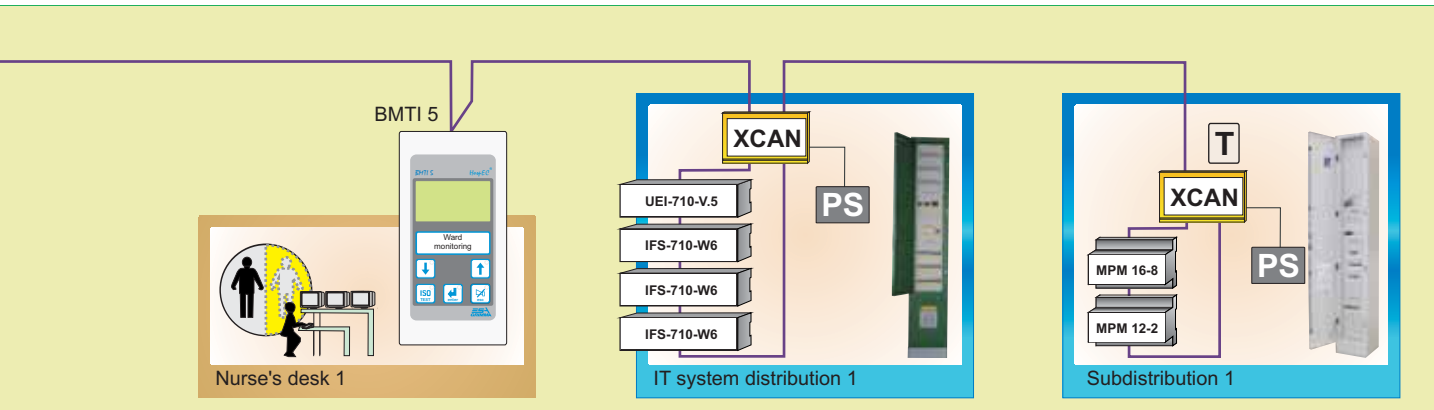

XCAN

- Terminal adapter XCAN in each distributor with switchable termination resistor

T

- Termination is switched on, a CAN terminal adapter with switchable termination resistors is integrated in the panels

PS

- Power supply pack 24 V DC to power the devices and their CAN controllers in the distribution. If necessary, application of additional power supply packs for devices connected to the bus (e.g. BMTI 5). Panels have their own power supply packs.

CAN 0 - Abbreviation for "sectional bus segment" bus segment

CAN 1 - Abbreviation for "trans-sectoral bus segment" bus segment

Voltage monitoring device with change-over control *SPR-107-V.4*

Areas of application

As control and monitoring device for the switching between the general supply (GS) and the safety power supply (SS) in the automatic change-over modules (type *UEGL*).

Product description

- Monitoring of all voltages in single or three-phase systems regarding the compliance to tolerance limits specified for the device:
 - Voltage monitoring of the preferred incoming feeder, the second feeder as well as undervoltage or overvoltage after the change-over module
- Interruption monitoring of the N-line in three-phase systems (also with symmetrical network load)
- Switching control for mechanically latched contactors and motor-driven circuit breakers
- Monitoring the entire change-over module:
 - Internal device self-monitoring
 - Wire-break monitoring of the control circuits
 - Correct switch conditions and switch times of the load switch devices
- Voltage supply of the control circuits in connection with the control voltage change-over device *STU-107-V.3*
- LED displays of the operating conditions
- Text display (full graphics) for detailed information and menu display
- Operation via keys on the device
- Configuration with password-protected user-friendly menu, e.g.:
 - Triggering values of the voltage monitoring
 - Switch delay times
 - Actuation time of the load switch devices



SPR-107-V.4

3.1

Technical specifications

Monitored system	1/N AC 0...290 V/3/N AC 0...500 V/2 AC 0...500 V/each 50...60 Hz
Configurable values	
Triggering value, undervoltage	230/400 V system: 150...230 V/260...400 V
Triggering value, overvoltage	230/400 V system: 230...260 V/400...460 V
Switching delay time T_{vh}	0...999 s in 0.5 s steps
Reverse switching delay time T_{vr}	0...999 s in 0.5 s steps
No-load switching time (pause time) T_{nu}	0...999 s in 0.5 s steps
Actuation times for load switch devices	0.10...4 s in 0.02 s steps
Control	5 buttons
Configuration	By menu
Displays	Fully-graphical display (backlit) and LED
Messages	Plain text display/LED/signal relay/external by field bus (CAN) e.g. on the BMTI 5
Communication interface/protocol	CAN/CAN (2.0) acc. to ISO 11898
Supply voltage U_s	24 V DC (PELV)
Own consumption	About 7 W
Dimensions (H x W x D in mm)/mounting	90 x 160 x 73 (9 HP)/top-hat rail acc. to DIN EN 60715

Detailed specifications can be found in the technical documentation for the device.

Insulation, load and temperature monitoring device *ILT-107-V.4***Areas of application**

As monitoring device for medical IT systems in automatic switching and/or monitoring systems.

Product description

- Monitoring the:
 - Insulation resistance of a single-phase or three-phase AC 230 V IT system
 - Insulation resistance of a AC 24 V IT systems (operating theatre lamps, 1 or 2 single-phase circuits)
 - Load currents from single-phase or three-phase transformers through converters (three-phase systems with auxiliary device *RCM-W8*) and the
 - Temperature of the transformer (via PTC or opener contact)
- Monitoring of all measurement connection lines
- Internal device self-monitoring
- Can be upgraded with additional devices, an *IFS-710-DSG* (test signal generator) and at least an *IFS-710-W6* (insulation fault detection device), as an insulation fault detection system. The display of the faulty outgoing circuit (cutout designation) is then displayed on the device.
- Complete documentation of faults in a history memory, RTC-integrated
- LED displays of the operating conditions
- Text display (full graphics) for detailed information and menu display
- Operation via keys on the device
- Configuration with password-protected user-friendly menu, e.g.:
 - Triggering values of the insulation monitoring
 - Triggering values of the load current monitoring

*ILT-107-V.4*

3.2

Technical specifications

Monitored IT system	1 or 3 AC 120...265 V/1 AC 0...30 V/each 50...60 Hz
Configurable values	
Triggering values of the insulation monitoring 230 V	50...500 kΩ
Triggering values of the insulation monitoring 24 V	100...500 kΩ
Triggering values of the load current monitoring	5...50 A with converter ILT-W in single-phase systems; 5...100 A with auxiliary device <i>RCM-W8</i> /Converters in three-phase systems
Temperature monitoring triggering value/return value	fixed: 120 °C, 4 kΩ/1.5 kΩ
Control	5 buttons
Configuration	By menu
Displays	Fully-graphical display (backlit) and LED
Messages	Plain text display/LED/signal relay/external by field bus (CAN) e.g. on the BMTI 5
Communication interface/protocol	CAN/CAN (2.0) acc. to ISO 11898
Supply voltage U_s	24 V DC (PELV)
Own consumption	About 7 W
Dimensions (H x W x D in mm)/mounting	90 x 160 x 73 (9 HP)/top-hat rail acc. to DIN EN 60715

Detailed specifications can be found in the technical documentation for the device.

Multifunctional change-over and monitoring device *UEI-710-V.5*

Areas of application

As control and monitoring device for the switching between the general supply (GS) and the safety power supply (SS) in the automatic change-over modules (type *UEI-710*) and IT system connected to it with integrated test signal generator and insulation fault detection system.

Product description

- Monitoring of all voltages in single-phase systems regarding the compliance to tolerance limits specified for the device:
 - Voltage monitoring of the preferred incoming feeder, the second feeder as well as undervoltage or overvoltage after the change-over module
- Switching control for mechanically latched contactors
- Monitoring the entire change-over module:
 - Internal device self-monitoring
 - Wire-break monitoring of the control circuits
 - Correct switch conditions and switch times of the load switch devices
- Realising the voltage supply of the control circuits (with integrated control voltage switching)
- Monitoring of all measurement connection lines
- Monitoring the recurring check and triggering a “silent alarm” in case it is exceeded
- Monitoring the
 - Insulation resistance of a single-phase AC 230 V IT system
 - Load currents of the IT transformer by converter
 - Temperature of the transformer (via PTC or opener contact)
- Integrates test signal generator, in connection with *IFS-710-W6* (insulation fault detection devices) realisation of a complete insulation fault detection system
- Internal device self-monitoring
- Complete documentation of faults in a history memory, RTC-integrated
- Complete pluggable connecting contact – Exchanging the device without switching off the consumer is possible



UEI-710-V.5

Technical specifications

Monitored system (voltage)	1/N AC 0...290 V/50...60 Hz
Monitored IT system	AC 120...265 V/50...60 Hz
Configurable values	
Triggering value, undervoltage	150...230 V
Triggering value, overvoltage	230...260 V
Switching delay time Tvh	0...20 s in 0.2 s steps
Reverse switching delay time Tvr	0...20 s in 0.2 s steps
No-load switching time (pause time) Tnu	0...20 s in 0.2 s steps
Triggering values of the insulation monitoring 230 V	50...250 kΩ
Triggering values of the load current monitoring	5...50 A with converter ILT-W
Temperature monitoring, triggering value/return value	fixed: 120 °C, 4 kΩ/1.5 kΩ
Insulation fault detection system	With <i>IFS-710-W6</i> outgoing feeder circuit-oriented fault detection, max. 96 channels
Test current limited to maximum	1 mA
Control	Buttons
Configuration	By menu
Displays	Fully-graphical display (backlit) and LED
Messages	Plain text display/LED/signal relay/external by field bus (CAN) e.g. on the BMTI 5
Communication interface/protocol	CAN/CAN (2.0) acc. to ISO 11898
Supply voltage U_s	230 V AC 50 Hz
Own consumption	About 5 W
Dimensions (H x W x D in mm)/mounting	90 x 160 x 73 (9 HP)/top-hat rail acc. to DIN EN 60715

Detailed specifications can be found in the technical documentation for the device.

Insulation fault detection device *IFS-710-W6*

Areas of application

For creation of an insulation fault detection system in systems for medical locations.

The devices always combine to a functional unit with a test signal generator (*IFS-710-PSG*/integrated in the *UEI-710-V.5*) and an insulation, load and temperature monitoring device (*ILT-107-V.4*) or a multifunctional change-over and monitoring device (*UEI-710-V.5*).

Product description

- Test current detection with integrated current converters
- 6 measuring channel
- Parallel measurement value logging and processing, no multiplex process
- Compact construction
- Internal device self-monitoring
- Communication with corresponding test signal generator (*IFS-710-PSG/UEI-710-V.5*) via standard field bus (CAN)
- Configuration using the device *UEI-710-V.5* is possible

3.4



IFS-710-W6

Technical specifications

Number of measuring channels	6 (measurement converter integrated)
Number of measuring channels per IT system	Maximum 132 (96 with <i>UEI-710-V.5</i>)
Measurement value logging	Parallel, no multiplex process
Fault detection time	About 3 sec.
Triggering values of the test current	0.5 mA
Monitored system	
Rated voltage	AC 20...265 V
Rated frequency	45...400 Hz
Displays	LED
Messages	LED/field bus (CAN)
Communication interface/protocol	CAN/CAN (2.0) acc. to ISO 11898
Supply voltage U_s	24 V DC (PELV) via CAN bus
Own consumption	About 2.6 W
Dimensions (H x W x D in mm)/mounting	45 x 190 x 56 (11 HP)/top-hat rail acc. to DIN EN 60715

Detailed specifications can be found in the technical documentation for the device.

Test signal generator *IFS-710-PSG*

Areas of application

For creation of an insulation fault detection system in systems for medical locations.

The device always combines to a functional unit with at least one insulation fault detection device (*IFS-710-WG*) and an insulation, load and temperature monitoring device (*ILT-107-V.4*). Its functions are implemented likewise in the in multifunctional change-over and monitoring device (*UEI-710-V.5*).

3.5

Product description

- Start of the insulation fault detection process
- Creating the test signal
- Limiting the test current
- Control and evaluation of the connected insulation fault detection devices
- Internal device self-monitoring
- Communication with insulation fault detection devices via standard field bus (CAN)
- Display of the faulty power circuit for example on the *ILT-107-V.4*, *UEI-710-V.5*, *BMT1 S* or *AN2 OS*



IFS-710-PSG

Technical specifications

Number of measuring channels per IT system	Max. 132
Maximum test current	1 mA
Test cycle	Variable
Monitored system	
Rated voltage	AC 20...265 V
Rated frequency	45...400 Hz
Displays	LED
Messages	LED/signal relay/field bus (CAN)
Communication interface/protocol	CAN/CAN (2.0) acc. to ISO 11898
Supply voltage U_S	24 V DC (PELV) via CAN bus
Own consumption	About 3 W
Dimensions (H x W x D in mm)/mounting	90 x 52.5 x 73 (3 HP)/top-hat rail acc. to DIN EN 60715

Detailed specifications can be found in the technical documentation for the device.

Residual current monitoring device *RCM-W6*

Areas of application

In earthed systems (TN/TT systems) for monitoring and evaluating fault currents flowing to earth or other paths (detected as residual currents). This compact device with integrated converters is mainly used in the distribution outgoing feeders for consumers and systems. In combination with other devices of the *RCM* series, display devices or devices for data coupling to third-party systems, it forms a complete residual and operating current monitoring system.

Product description

- Residual current detection with integrated current converters (fault currents acc. to IEC 60755 type A)
- 6 measurement channels, compact construction
- Parallel measurement value logging and processing, no multiplex process
- True root mean squared
- Convenient configuration options for each channel, such as:

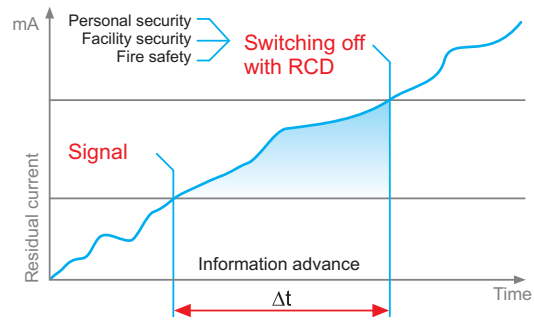

Schematic diagram of residual current measurement when exceeding threshold values

- Value of the warning threshold (exiting the normal range)
- Value of the triggering threshold (reaching the critical range)
- Time delay for respective warning and triggering messages (in case the threshold values are exceeded)
- Adjustable hysteresis range for triggering threshold
- Internal device self-monitoring
- LED displays of the operating conditions



RCM-W6

Technical specifications

Number of measuring channels	6 (measurement converter integrated)
Number of measuring channels in the system	Max. 384 (per bus segment)
Measurement value logging	Parallel, true root mean squared
Evaluation	Residual currents
Evaluation range of residual current	10...1000 mA
Converter rated voltage	AC 20...720 V
Converter rated frequency	50...60 Hz
Converter rated current	50 A
Configurable values per channel	Warning and triggering threshold/hysteresis for triggering threshold/time delay for messages
Configuration	PC-Software " <i>HoqEC®</i> configurator" (via USB-CAN adapter), display and configuration device <i>ANZ 05</i> (via field bus CAN)
Displays	LED
Messages	LED/external by field bus (CAN) e.g. on the <i>ANZ 05</i>
Communication interface/protocol	CAN/CAN (2.0) acc. to ISO 11898
Supply voltage U_s	24 V DC (PELV) via CAN bus
Own consumption	About 2.6 W
Dimensions (H x W x D in mm)/mounting	45 x 190 x 56 (11 HP)/top-hat rail acc. to DIN EN 60715

Detailed specifications can be found in the technical documentation for the device.

Residual and operational current monitoring device *RCM-W8*

Areas of application

In earthed power supply systems (TN/TT systems) for monitoring and evaluating fault currents flowing to earth or other paths (detected as residual currents) and for operational currents (also in IT systems). The device, with attachable converters, is primarily employed in incoming and outgoing feeders of distributors for consumers and systems as well as for the monitoring of straying currents in TN-S systems (PEN and N lines) and at central earthing points. In combination with other devices of the *RCM* series, display devices or devices for data coupling to third-party systems, it forms a complete residual and operating current monitoring system.

3.7

Product description

- Residual and operating current detection with attachable current converters (fault currents acc. to IEC 60755 type A)
- 8 measuring channels, freely configurable for residual and operating current detection
- Parallel measurement value logging and processing, no multiplex process
- True root mean squared
- Convenient configuration options for each channel, such as:

*RCM-W 8*

- Values of the lower and upper warning threshold (exiting the normal range) = window function during operating current detection
- Value of the lower and upper triggering threshold (reaching the critical range)
- Time delay for respective warning and triggering messages (in case the threshold values are exceeded)
- Adjustable hysteresis range for triggering thresholds
- Internal device self-monitoring
- LED displays of the operating conditions

Technical specifications

Number of measuring channels	8 (converter can be connected to device)
Number of measuring channels in the system	Max. 128 (per bus segment)
Measurement value logging	Parallel, true root mean squared
Evaluation	Residual and operating current (channels freely configurable)
Evaluation range of residual current	10...1000 mA
Evaluation range of operational current	1...4000 A (depends on converter)
Converter types/transmission ratio	Residual current measurement converter series DW or DW-T/700/1, operational current measurement converter e.g. series ASK or KBU/100/1 up to 4000/1
Converter rated voltage	AC 20...720 V
Converter rated frequency	50...60 Hz
Converter rated current	1...4000 A (depends on type)
Configurable values per channel	Warning and triggering threshold/hysteresis for triggering threshold/time delay for messages (0...10 s)/reset delay for messages (0...10 s)/window function for operational current measurement
Configuration	PC-Software " <i>HoytEC®</i> configurator" (via USB-CAN adapter), display and configuration unit <i>AN2 05</i> (via field bus CAN)
Displays	LED
Messages	LED/relay/CAN bus
Communication interface/protocol	CAN/CAN (2.0) acc. to ISO 11898
Supply voltage U_s	24 V DC (PELV)
Own consumption	About 5 W
Dimensions (H x W x D in mm)/mounting	90 x 105 x 73 (6 HP)/top-hat rail acc. to DIN EN 60715

Detailed specifications can be found in the technical documentation for the device.

Operating and annunciator terminal *BMTI 5*

Areas of application

The device serves to display operational and fault message of monitored power supply system of medical locations and other devices of the *HoepEC®* system. Furthermore, the device makes it possible to trigger the test function of connected IT system monitoring devices.

Product description

- Display of operational, warning and fault messages from devices from the *HoepEC®* system
- Text display (full graphics) for detailed information and menu presentation, multicoloured, backlit
- Quick recognition of message priorities by colour changes of the display
- Operation via keys on the device and intuitive menu interface
- Preallocation with standard message texts
- Display of up to 1000 different operational conditions
- Input of individual message texts
- Message memory for 1000 messages in a null-voltage safe memory (EEPROM)
- Date and time with RTC
- Exchangable storage medium for history/firmware configuration (MICRO-SD card)



BMTI 5

- Configuration via integrated mini USB or CAN interface
- Closed, multilayered and permanently stable foil surface, resistant against cleaning and disinfectant agents, UV-proof
- High protection class of the operating interface (IP54)

Technical specifications

Source of the signals	All devices of the <i>HoepEC®</i> system (e.g. with <i>MPM 16-8</i> also from third-party systems)
Number of different messages	Max. 1000 individual lines of text
Display	Fully-graphical display (multicoloured, backlit)
Messages	Plain text display/display of the message priority by colour change of the display/horn/CAN bus
Message texts	Standard texts (default)/individual texts
Message memory	1000 integrated, with date/time
Control	Foil keyboard
Test functions	For IT system monitoring devices
Configuration	By menu/PC configuration software via CAN bus/integrated mini USB interface
Relay output	1 exchanger as omnibus fault message
Further inputs/outputs	16, freely configurable as input/output (open collector)
Special feature	- Several <i>BMTI 5s</i> can be combined to groups for common acknowledgments and monitor their functions mutually - Gateway function for connecting two CAN bus segments
Communication interface/protocol	2 x CAN/CAN (2.0) acc. to ISO 11898
Operating interface	Multilayered foil surface, resistant against cleaning and disinfectant agents
Supply voltage U_s	24 V DC (PELV) by standard via CAN bus
Own consumption	About 5 W
Protection class according to DIN EN 60529	IP30/IP20 (built-in components/terminals), IP54 (operating interface)
Dimensions front plate (H x W x D in mm)/mounting	171 x 86/cavity wall/in-wall/on-wall

Detailed specifications can be found in the technical documentation for the device.

Annunciator and control panel series *FolioTec***Areas of application**

The panels are employed in all areas. For example, to display operational and fault messages of IT systems monitors, switching controllers, for the display of measured values and messages from all other devices of the *HoypEC®* system, for messages from third-party components – such as the medical gas supply, for operating table control, integration of voice communication, lighting and A/C control, mapping and control of further processes of the complete system.

Product description

Freely configurable buttons and LED display can be combined to function blocks with up to 10 placement slots and assigned to a certain system (e.g. the air conditioning) (function block technique FBT).

A large, fully graphical LC display is available for the text output. Freely-configurable multifunctional illuminated buttons are assigned to it in blocks with up to 7 placement slots (text technique LCD).

For displaying building floor plans or process diagrams, multifunctional illuminated buttons or signal LEDs can be placed freely or additionally in table format (layout plan technique LPT).

All techniques can be flexibly combined in a panel.

- Simple and clearly laid out reporting, operation and monitoring
- Freely configurable functions for LED; pushbuttons and multifunctional illuminated buttons (touch or lock-in feature)
- Clearly arranged display of information by large, backlit fully-graphical display
- Display of operational, warning and fault messages from devices from the *HoypEC®* system
- Integration possible of all process controls and monitoring
- General processing of the system's data, no commitment to predefined warning and operational messages
- Process link to standard systems such as CAN, EIB, LON®, PLC, binary, RS232, Modbus, TCP/IP via separate gateways
- Installation options for intercom systems, telephones, loading stations for operating table controls
- Configurable acoustic messages
- Installation options for timer systems (e.g. with daytime, stopwatch, counter) and digital displays (e.g. room temperature)
- Display of individual message texts, message memory
- Function changes for operating and display elements can also be conducted later without a problem for standard employment of special hardware and software.

- Closed, multilayered and permanently stable foil surface, resistant against cleaning and disinfectant agents, UV-proof
- Dimensions can be adapted to tile raster
- Attractive design, individual configuration possibilities of the foil surface
- High protection class of the operating interface (IP54)



Various panel variants

Technical specifications

Source of the signals	Devices of the <i>Hot-EC</i> ® system/third-party systems
Number of different messages	Max. 1000 individual lines of text
Display	Fully-graphical display 240 x 108 pixel (backlit) and LED
Messages	Plain text display/LED/horn
Message texts	Individual texts
Message memory	Integrated, with RTC, secured against voltage failures
Control	Foil keyboard
Further installation possibilities	For example operating table controls, timers (analogue/digital display) with daytime/stopwatch/counter, devices for voice communication, digital displays
Configuration	PC configuration software via USB-CAN adapter
Relay outputs	Possible
Special feature	Freely configurable functions for LED; pushbuttons and multifunctional illuminated buttons (touch or lock-in feature)
Process integrations	CAN, via gateways/MPM: EIB, LON®, PLC, binary, RS232, Modbus®, TCP/IP
Communication interface (standard)/protocol	2 x CAN/CAN (2.0) acc. to ISO 11898
Operating interface	Closed, multilayered and permanently stable foil surface, resistant against cleaning and disinfectant agents, UV-proof
Supply voltage U _s	24 V DC (PELV) (power supply pack AC 230 V/DC 24 V, 48 VA integrated)
Own consumption	Depends on stage of expansion
Protection class according to DIN EN 60529	IP30/IP20 (built-in components/terminals), IP54 (operating interface)
Frame/On-wall case	Aluminium, eloxidised
Dimensions (H x W x D in mm)	Max. 800 x 800 x 85 or max. 800 x 800 x 110
Mounting	Cavity wall/in-wall/control cabinet doors or on-wall

3.9



Display and configuration device *ANZ 05*

Areas of application

For displaying measured values and messages of all devices from the *HoyfEC®* system, for messages from third-party systems as well as for configuration of residual and operational current monitoring devices *RCM*.

Product description

- Display of message of all device of the *HoyfEC®* system and of third-party systems
- Display of measured values of the residual and operational current monitoring devices *RCM*, configuration of these devices
- Clearly arranged display of information by large, backlit fully-graphical display
- Freely configurable message texts
- Divided into 3 message levels: operational, warning and fault messages
- Adjustable acoustic messages
- Message memory
- 2 communication interfaces (CAN) with gateway function for connecting two bus segments



ANZ 05

- 2 relay outputs, configurable for example for load shedding control
- Simple, clearly laid out and intuitive operation and menu interface
- Buttons and display elements transparently backlit
- Stable foil surface

Technical specifications

Source of the signals	Devices of the <i>HoyfEC®</i> system/third-party systems
Number of different message texts	Max. 1000 individual lines of text
Displays	Fully-graphical display 240 x 108 pixel (backlit) and LED
Messages	Plain text display/LED/relay/horn
Message texts	Individual texts
Message memory	Integrated, with RTC, secured against voltage failures
Control	5 buttons, foil keyboard backlit
Functions for device of the RCM series	<ul style="list-style-type: none"> - Display of measured values - Warning and triggering messages - Configuration of 10 different setting values of control commands each
Configuration	PC configuration software via USB-CAN adapter
Relay outputs	2, fault message or for load shedding control
Special feature	Gateway function for connecting two CAN bus segments
Process integrations	CAN, via gateways/MPM: EIB, LON®, PLC, binary, RS232, Modbus®
Communication interface/protocol	2 x CAN/CAN (2.0) acc. to ISO 11898
Operating interface	Closed, multilayered and permanently stable foil surface, resistant against cleaning and disinfectant agents, UV-proof
Supply voltage U_s	24 V DC (PELV)
Own consumption	About 6 W
Protection class according to DIN EN 60529	IP30/IP20 (built-in components/terminals), IP54 (operating interface)
Frame	Aluminium, eloxidised
Dimensions (H x W x D in mm)	195 x 295 x 90 (front plate x installation depth incl. terminals)
Mounting	Cavity wall/control cabinet doors

Detailed specifications can be found in the technical documentation for the device.

Digital I/O-device *MDM 12-2*

Areas of application

To register digital signal via physical inputs or via the field bus (CAN). The signals can be linked logically and are available for control purposes on switch outputs and on the field bus. Using convenient dimming functions and interfaces for electronic ballasts (EB), these devices are mainly used for lighting control.

Product description

- Configurable I/O-device with independent logic function
- Inputs assignable with potential-free contacts – also standard installation switches and installation pushbuttons
- Outputs as relay outputs
- 2 digital potentiometer for controlling dimmable EB with 1...10 V interface
- Convenient dimming and control functions – special for medical locations
- Single fault security of the devices



MDM 12-2

- Internal device self-monitoring
- LED displays of the operating conditions

3.11

Technical specifications

Physical inputs	12
Type of inputs	Potential-free or non-floating (max. 24 V DC)
Physical outputs	2
Type of outputs	Relay contacts AC 230 V/1500 VA
Dimmer outputs	2 digital potentiometer for controlling dimmable EB with 1...10 V interface
Functions	<ul style="list-style-type: none"> - Reading of relay messages in the standard field bus (CAN) - Light control and further control functions by installation buttons/switches or operating panels - Reading and processing of messages from the field bus - Output of messages/commands at switch outputs and on the field bus - Light scenario control (max. 2 circuits with 4 scenarios each), which can be saved by the user - Extensive dimming functions (e.g. joint or individual dimming of both circuits single or double switch versions, soft-on and soft-off effect of the circuits) - "Custodian function" for on-site switch can be added - Switching on the safety lighting during network backup operation (only SS), depending on the switch position of the light circuits before network interruption. (If only GS circuit was in operation before network failure, then the SS circuit should go into operation automatically.) To do so, the device communicates with the responsible voltage monitoring. - If dimming was down, then the SS circuit will be set to 100 % automatically in case of GS malfunction.
Software functions	<ul style="list-style-type: none"> - Free assignment of input/output channels (operational/warning/fault messages) - Defined initial conditions after reset (low, high, last status before reset) - Logical links of variables (physical inputs of the device and status messages from the field bus) - Control functions for safety and general lighting (SS and GS circuits) - 120 logical inputs (messages from the field bus) can be processed - Logic operands AND, OR, XOR, NOT - Up to 20 operands per logic formula, 5 timer operands, reset and output operand - Stand-alone operation (without bus connection) - Failure detection of other field bus device (sign of life) - 32 Switch clock channels with integrated real time clock (RTC)
Configuration	PC-Software " <i>HospEC®</i> configurator" (via USB-CAN adapter), for stand-alone application also by DIP switch
Displays	With LED: Status displays of the inputs/outputs/operation/bus
Communication interface/protocol	CAN/CAN (2.0) acc. to ISO 11898
Supply voltage U_s	24 V DC (PELV)
Own consumption	About 3.6 W
Dimensions (H x W x D in mm)/mounting	90 x 70 x 73 (4 HP)/top-hat rail acc. to DIN EN 60715

Detailed specifications can be found in the technical documentation for the device.

Digital I/O-device *MDM 16-8*

Areas of application

To register digital signal via physical inputs or via the field bus (CAN). The signals can be linked logically and are available for control purposes on switch outputs and on the field bus. Employment for example for the lighting control, registering of switch positions – such as auxiliary contacts of power switches, potential-free signal contacts of third-party systems, general control tasks.

Product description

- Configurable I/O-device with independent logic function
- Inputs assignable with potential-free contacts – also normal light switches or buttons
- Outputs as relay outputs
- Single fault security of the devices
- Internal device self-monitoring
- LED displays of the operating conditions



MDM 16-8

Technical specifications

Physical inputs	16 (2 groups of 8)
Type of inputs	Potential-free or non-floating (max. 24 V DC)
Physical outputs	8
Type of outputs	Relay contacts AC 230 V/1500 VA
Functions	<ul style="list-style-type: none"> - Reading of relay messages in the standard field bus (CAN) - Light control and further control functions by installation buttons/switches or operating panels - Reading and processing of messages from the field bus - Switching on the safety lighting during network backup operation (only SS), depending on the switch position of the light circuits before network interruption. (If only GS circuit was in operation before network failure, then the SS circuit should go into operation automatically.) To do so, the device communicates with the responsible voltage monitoring.
Software functions	<ul style="list-style-type: none"> - Free assignment of input/output channels (operational/warning/fault messages) - Defined initial conditions after reset (low, high, last status before reset) - Logical links of variables (physical inputs of the device and status messages from the field bus) - Control functions for safety and general lighting (SS and GS circuits) - 120 logical inputs (messages from the field bus) can be processed - Logic operands AND, OR, XOR, NOT - Up to 20 operands per logic formula, 5 timer operands, reset and output operand - Stand-alone operation (without bus connection) - Failure detection of other field bus device (sign of life) - 32 Switch clock channels with integrated real time clock (RTC)
Configuration	PC-Software " <i>HoqEC®</i> configurator" (via USB-CAN adapter)
Displays	With LED: Status displays of the inputs/outputs/operation/bus
Communication interface/protocol	CAN (2.0) acc. to ISO 11898
Supply voltage U_s	24 V DC (PELV)
Own consumption	About 5 W
Dimensions (H x W x D in mm)/mounting	90 x 105 x 73 (6 HP)/top-hat rail acc. to DIN EN 60715

Detailed specifications can be found in the technical documentation for the device.

Digital I/O-device *MPM 32-Vario*

Areas of application

To register digital signal via physical inputs or via the field bus (CAN). The signals can be linked logically and are available for control purposes on open collector outputs and on the field bus. All 32 channels can be freely used as inputs or outputs upon configuration. Employment for example for the lighting control, registering of switch positions – such as auxiliary contacts of power switches, potential-free signal contacts of third-party systems, general control tasks, connection to the central building control system.

Product description

- Configurable I/O-device with independent logic function
- Inputs assignable with potential-free contacts – also normal light switches or buttons
- Outputs as open-collector output, short circuit-proof and overload safe
- 32 channels optionally usable as inputs or outputs
- Single fault security of the devices
- Internal device self-monitoring
- LED displays of the operating conditions



MPM 32-Vario

3.13

Technical specifications

Physical inputs	32* (4 groups of 8)
Type of inputs	Non-floating (24 V DC = auxiliary voltage)
Physical outputs	32* (* channels optionally configurable as inputs or outputs)
Type of outputs	Open collector (24 V DC, 350 mA, short circuit-proof)
Functions	<ul style="list-style-type: none"> - Reading of relay messages in the standard field bus (CAN) - Light control and further control functions by installation buttons/switches or operating panels - Reading and processing of messages from the field bus - Special control functions for the safety lighting (such as <i>MPM 12-2/MPM 16-8</i>)
Software functions	<ul style="list-style-type: none"> - Free assignment of input/output channels (operational/warning/fault messages) - Defined initial conditions after reset (low, high, last status before reset) - Logical links of variables (physical inputs of the device and status messages from the field bus) - Control functions for safety and general lighting (SS and GS circuits) - 120 logical inputs (messages from the field bus) can be processed - Logic operands AND, OR, XOR, NOT - Up to 20 operands per logic formula, 5 timer operands, reset and output operand - Stand-alone operation (without bus connection) - Failure detection of other field bus device (sign of life) - 32 Switch clock channels with integrated real time clock (RTC)
Configuration	PC-Software " <i>HospEC®</i> configurator" (via USB-CAN adapter)
Displays	With LED: Status displays of the inputs/outputs/operation/bus
Communication interface/protocol	CAN/CAN (2.0) acc. to ISO 11898
Supply voltage U_s	24 V DC (PELV) (24 V DC auxiliary voltage for inputs/outputs necessary)
Own consumption	About 5 W
Dimensions (H x W x D in mm)/mounting	90 x 105 x 73 (6 HP)/top-hat rail acc. to DIN EN 60715

Detailed specifications can be found in the technical documentation for the device.

Software *HoypEC*[®] configurator

Areas of application

For configuration of devices of the *HoypEC*[®] system. The configuration created by the software is sent from the PC/laptop to the devices (field devices) connected to the field bus (CAN). Likewise, the values already set in the field devices can be read out and be displayed, edited and saved in the *HoypEC*[®] configurator.

The connection between the PC/Laptop and the field devices located on the CAN bus is established via USB interface through a USB-CAN adapter (CAN dongle) and via a permanently installed CAN-Bus terminal adapter in a distribution.

The *HoypEC*[®] configurator acts as the basic module of the configuration software; for every device family (currently *MPM/RCM*) there is a plug-in available. Expansion to other devices is in preparation.

The user interface of the program is designed for a simple and clearly laid out presentation. All devices assigned to a project are displayed in a tree structure. Additional designations, e.g. about installation sites, are possible to facilitate quick access.

The settings are made in the configuration windows, specific for the device. The help menu provides examples and explanations as needed.

When do you need the software?

A new system is always handed over to you as a turnkey system upon commissioning. Our service department is also always at your disposal to implement changes to the device settings. Using the *HoypEC*[®] configurator, operators have the possibility of making necessary modifications to the device settings by themselves.

System requirements

- Intel Pentium 3/AMD Athlon
- 128 MB RAM
- 30 MB free memory on the hard disk
- USB 2.0 interface
- Microsoft[®] Windows XP operating system

3.14

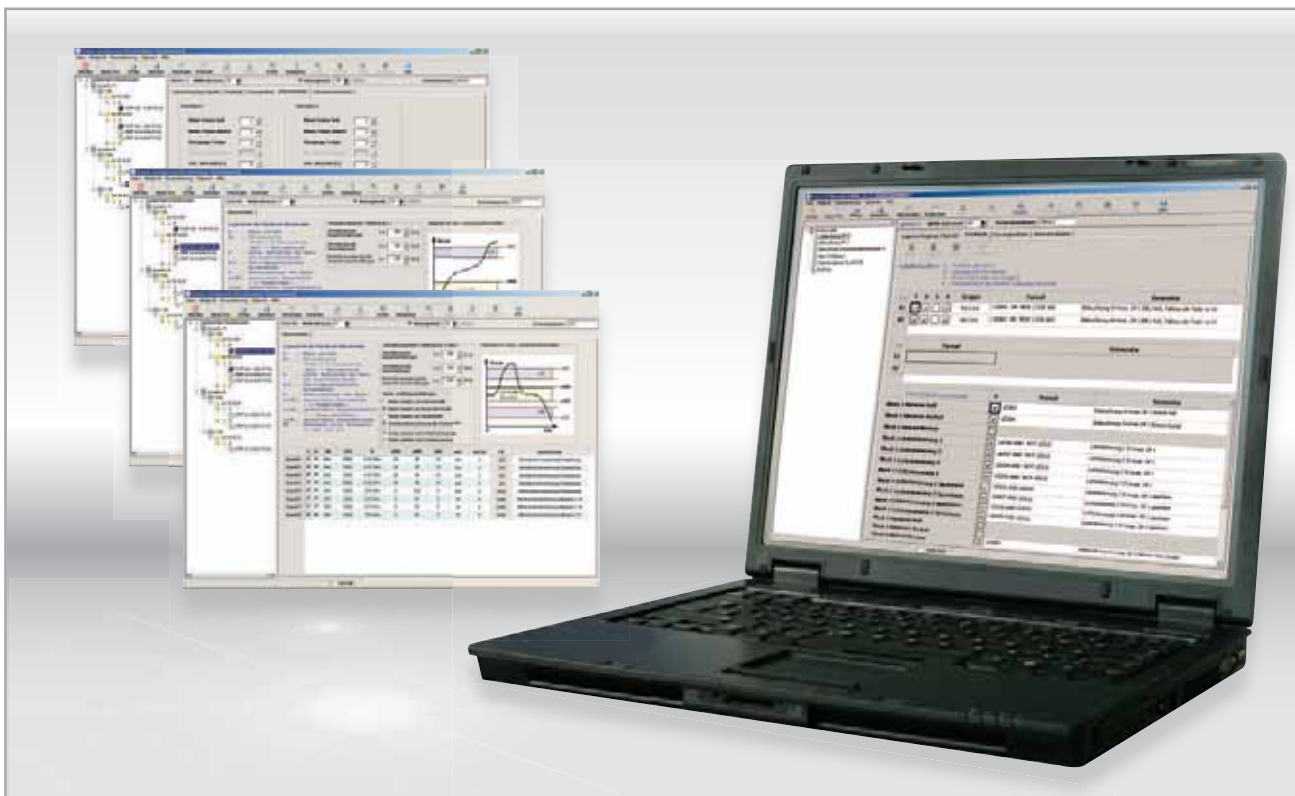

Sample illustrations for configuration software and sample system *HoypEC*[®]

Sample system *HayEC*[®]

Our fully functional sample systems can be used for test and demonstration purposes. In minimal space, the following components are encompassed with all necessary accessories:

- Change-over and monitoring module *UEI-710* with IT system transformer and integrated insulation fault detection system (complete IT system)
- Operating and annunciator terminal *BMTI 5*
- Digital I/O-device *MPM 16-8*
- Digital I/O-device *MPM 12-2* with dimming control
- Annunciator and control panel *FolioTec*
- Residual and operational current monitoring device *RCM-W8*
- Residual current monitoring device *RCM-W6*
- 2 lights with EB for simulating the “surround lighting in the operating theatre”, etc.
- USB-CAN configuration interface
- Devices connected with field bus (CAN)

All functionalities of the devices can be tested and are visible under realistic conditions. The user can reconfigure the devices and test the effects of the own settings.



Standards

IEC60364-7-710

International:

IEC 60364-7-710:2002-11

Electrical installations of buildings – Part 7-710:
Requirements for special installations or locations –
Medical locations

DIN VDE 0100-710

Deutschland:

DIN VDE 0100-710:2002-11

Errichten von Niederspannungsanlagen
Anforderungen für Betriebsstätten, Räume und Anlagen
besonderer Art Teil 710: Medizinisch genutzte Bereiche

HTM2007

Großbritannien:

Health Technical Memorandum 2007

Electrical services supply and distribution

NEN1010-710

Niederlande:

NEN 3134 – Veiligheidsbepalingen voor laagspannings-
installaties in medisch gebruikte ruimten

NFPA99

USA:

NFPA 99 – Standard for Health Care Facilities

Illustrations

References	Page
Left and middle Foto Geuther, right fotosearch	Cover
ESA	2
2 x Foto Geuther, ESA	3
ESA	4, 5
Foto Geuther	6
ESA	7
Foto Geuther	8
ESA	9, 10
Foto Geuther, ESA	11
ESA	12
Foto Geuther	13, 14
ESA	15, 16
Foto Geuther	17
Foto Geuther, ESA	18
ESA	19
Foto Geuther, ESA	20
ESA	21
Foto Geuther, ESA	22
ESA	23–31
Foto Geuther	31–36
Foto Geuther, ESA	37
Foto Geuther	38
ESA	39–41
Foto Geuther	41–44
ESA	45
3 x ESA, Foto Geuther	46
Foto Geuther	47, 50

Originator:

- Foto Geuther – www.foto-geuther.de
- fotosearch – www.fotosearch.com
- ESA – Elektroschaltanlagen Grimma GmbH

Table of contents

Chapter	Page
Our sales offices in your vicinity	2
The corporation: ESA Elektroschaltanlagen Grimma GmbH	3
Complete power supply solutions for medical locations with the regulation and control system <i>HotEC®</i>	4
1.1 Main distribution board LVMD	6
1.2 Facility main distribution board FMDB	8
1.3 IT system distribution board <i>IPS</i> for areas of group 2	10
1.4 Subdistributor SD for areas of group 0 and 1 as well as for supplying general areas	12
2.1 Change-over module <i>UEGL</i> for main building distribution boards	14
2.2 Change-over and monitoring module <i>UEI-710, ÜEI-710</i> for IT system distribution board	16
2.3 Insulation fault detection system <i>IFS</i>	18
2.4 Residual and operational current monitoring system <i>RCM</i>	20
2.5 Display and operating systems <i>FolioTec, BMTI S, ANZ OS</i>	22
2.6 Lighting control/Linking to third-party systems with digital input/output modules <i>MPM</i>	24
2.7 Standard field bus CAN	28
3.1 Voltage monitoring device with change-over control <i>SPR-107-V.4</i>	32
3.2 Insulation, load and temperature monitoring device <i>ILT-107-V.4</i>	33
3.3 Multifunctional change-over and monitoring device <i>UEI-710-V.5</i>	34
3.4 Insulation fault detection device <i>IFS-710-WG</i>	35
3.5 Test signal generator <i>IFS-710-PSG</i>	36
3.6 Residual current monitoring device <i>RCM-WG</i>	37
3.7 Residual and operational current monitoring device <i>RCM-W8</i>	38
3.8 Operating and annunciator terminal <i>BMTI S</i>	39
3.9 Annunciator and control panel series <i>FolioTec</i>	40
3.10 Display and configuration device <i>ANZ OS</i>	42
3.11 Digital I/O-device <i>MPM 12-2</i>	43
3.12 Digital I/O-device <i>MPM 16-8</i>	44
3.13 Digital I/O-device <i>MPM 32-Vario</i>	45
3.14 Software <i>HotEC®</i> configurator	46
Standards	48
Service	50
Sales partner	52

Service – Hospital



Our services for you

You have questions or need a personal consultation on your specific problems?

We can help you quickly and straightforward.

- Service weekdays
- Prompt and individual help
- Professional information and consultation

Our range of services

- Starting up of ESA products as well as third-party and competitor equipment
- System acceptance with technical experts
- Instruction for the operators
- On-site training
- Network and load analyses
- Troubleshooting
- Short-circuit current and selectivity calculations
- System modernisation
- Recurring inspections
- Insulation fault detection
- Spare parts deliveries
- Maintenance, maintenance contracts
- Documentation and retrofitting existing systems

Your benefit

- Ensuring system and operational reliability
- High level of equipment availability
- Personal further training regarding system functions and operation

Our service team in Vietnam

General questions

Service

Monday–Friday 7:00 am – 6:00 pm

Telephone: +84 4 6664 2225

Fax: +84 4 6664 2221

E-mail: info@sisys.vn

Technical questions

Product management

Monday–Friday 7:00 am – 4:00 pm

Telephone: +84 4 6664 2225

Fax: +84 4 6664 2221

E-mail: info@sisys.vn

Hotline: 0962872211

